

DuraLabel 9000

**THERMAL TRANSFER / DIRECT THERMAL
BAR CODE PRINTER**

Printer Manual

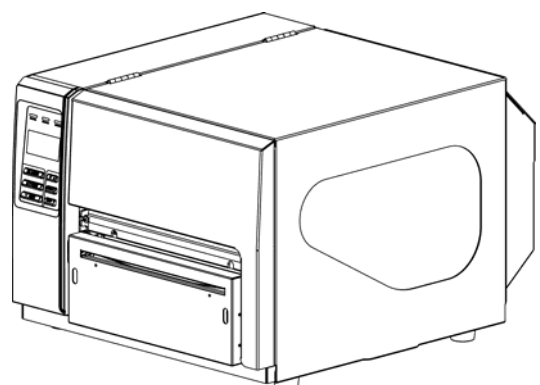

Contents

1. Introduction	1
1.1 Product Introduction	1
1.2 Compliances	1
2. Operations Overview	3
2.1 Unpacking and Inspection	3
2.2 Printer Overview	4
2.2.1 Front View	4
2.2.2 Interior View	5
2.2.3 Rear View	6
2.3 Operator Controls	7
2.3.1 Front Panel Display	7
2.3.2 LED Indicators	7
2.3.3 Front Panel Keys	8
2.4 Setting Up the Printer	8
2.5 Loading Supply	9
2.6 Loading Ribbon	12
3. Menu Function	15
3.1 Setup Menu Overview	16
3.1.1 Printer Setup	17
3.1.2 Sensor	23
3.1.3 Serial Comm.	31
3.1.4 Ethernet	34
3.2 File Manager	37
3.2.1 File List	37
3.2.2 Avail. Memory	38
3.2.3 Del. All Files	38
3.3 Diagnostics	39
3.3.1 Print Config.	39
3.3.2 Dump Mode	40
3.3.3 Rotate Cutter	41
3.4 Language	41
3.5 Service	42
3.5.1 Initialization	42
1D bar code	44
2D bar code	44

6. Troubleshooting.....	46
6.1 Common Problems	46
7. Maintenance	49

1. Introduction

1.1 Product Introduction

Thank you for purchasing the DuraLabel® 9000 Industrial Sign and Label Printer.

The DuraLabel 9000 provides thermal transfer printing (TTP) on continuous and die-cut supplies. It produces quality signs and labels with 300 DPI resolution and prints at speeds up to 3 ips.

The DuraLabel 9000 includes a built-in high performance MONOTYPE IMAGING® True Type font engine and one CG Triumvirate Bold Condensed smooth font. With flexible firmware design, the True Type Font can be downloaded from a PC into the printer memory for printing labels. Besides the scalable font, it also provides a choice of five different sizes of alphanumeric bitmap font, OCR-A and OCR-B fonts.

1.2 Compliances

CE Class A:

EN55022:1998+A1:2000+A2:2003:

EN55024:1998+A1:2001+A2:2003:

EN 61000-4 SERIES REGULATIONS

ETSI EN 301 489-17:V1.2.1(2002-08)

FCC:

CFR 47, Part 15/CISPR 22 3RD EDITION:1997, Class A

<p>This device complies with Part 15 of the FCC Rules. Operation is subject to the following two conditions. (1) This device may not cause harmful interference, and (2) This device must accept any interference received, including interference that may cause undesired operation.</p>
--

(CAUTION: Danger of explosion if battery is incorrectly replaced. Replace only with the same or equivalent type recommended by the manufacturer. Dispose of used batteries according to the manufacturer instructions.)

Federal Communication Commission (FCC) Interference Statement

This equipment has been tested and found to comply with the limits for a Class B digital device, pursuant to Part 15 of the FCC Rules. These limits are designed to provide reasonable protection against harmful interference in a residential installation. This equipment generates, uses and can radiate radio frequency energy and, if not installed and used in accordance with the instructions, may cause harmful interference to radio communications. However, there is no guarantee that interference will not occur in a particular installation. If this equipment does cause harmful interference to radio or television reception, which can be determined by turning the equipment off and on, the user is encouraged to try to correct the interference by one of the following measures:

- Reorient or relocate the receiving antenna.
- Increase the separation between the equipment and receiver.
- Connect the equipment into an outlet on a circuit different from that to which the receiver is connected.
- Consult the dealer or an experienced radio/TV technician for help.

This device complies with Part 15 of the FCC Rules. Operation is subject to the following two conditions:

1. This device may not cause harmful interference, and
2. This device must accept any interference received, including interference that may cause undesired operation.

Information to User

To assure continued compliance (example - use only shielded interface cables when connecting to computer or peripheral devices), any changes or modifications not expressly approved by the party responsible for compliance could void the user's authority to operate this equipment.

WARNING

HAZARDOUS MOVING PARTS – KEEP FINGERS AND OTHER BODY PARTS AWAY

CAUTION

RISK OF EXPLOSION IF BATTERY IS REPLACED BY AN INCORRECT TYPE. DISPOSE OF USED BATTERIES ACCORDING TO THE INSTRUCTIONS.

2. Operations Overview

2.1 Unpacking and Inspection

This printer has been specially packaged to withstand damage during shipping. Please carefully inspect the printer and its packaging upon receiving it. Please retain the packaging materials in case you need to return the printer.

Check that all DuraLabel 9000 equipment and supplies are present and undamaged before proceeding.

Equipment Checklist:

- DuraLabel 9000 printer unit with built-in cutter
- DuraLabel 9000 CD with printer driver, label templates and symbols
- DuraLabel 9000 User's Guide
- DuraLabel 9000 QuickStart Guide
- Power cord
- USB cord
- Supply guides (2)
- Ribbon core
- Ribbon guides with screws (2)

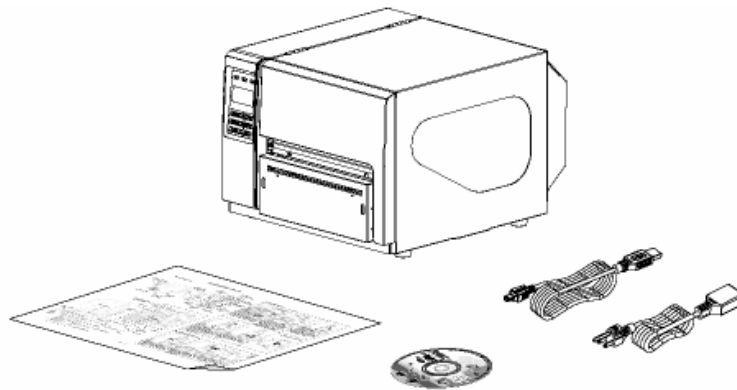

If any parts are missing, please contact the Graphic Products customer service department at 1-800-788-5572.

Please contact us for all your labeling needs. From standardized to custom labels, we're ready to provide the labeling supplies you need. Call 1-800-788-5572 today to get your labeling problems solved.

2.2 Printer Overview

2.2.1 Front View



1. LED indicators
2. LCD display
3. Front panel buttons
4. Printed label opening
5. Cutter mechanism
6. Printer cover

2.2.2 Interior View

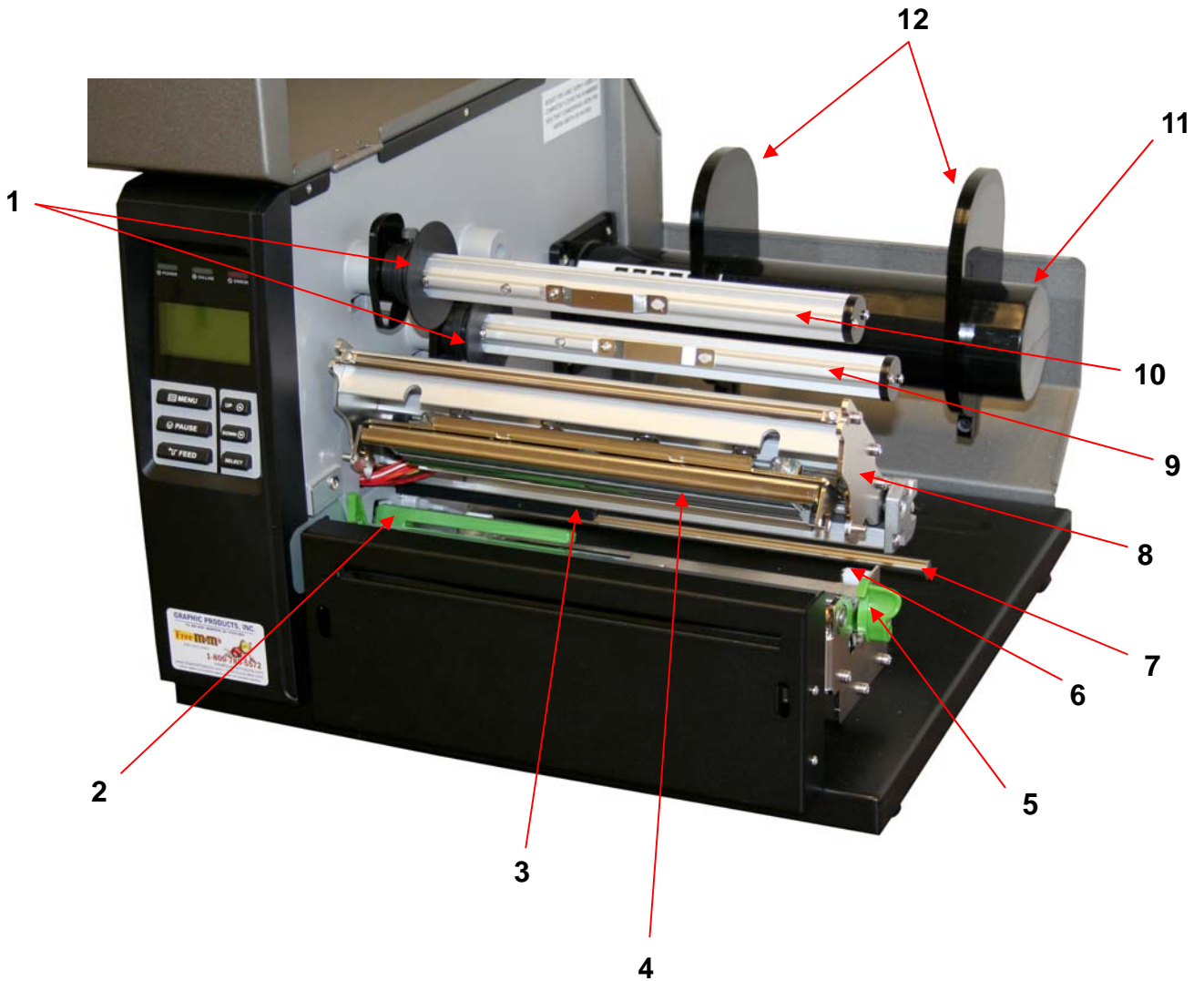

1. Ribbon Guides
2. Media Sensor (green)
3. Ribbon Sensor (black)
4. Print Head
5. Print Head Release Lever (green)
6. Adjustable Media Guides (white)
7. Media Guide Bar
8. Print Head Mechanism
9. Ribbon Spindle (back spindle)
10. Ribbon rewind spindle (front spindle)
11. Supply Bar
12. Supply Guides

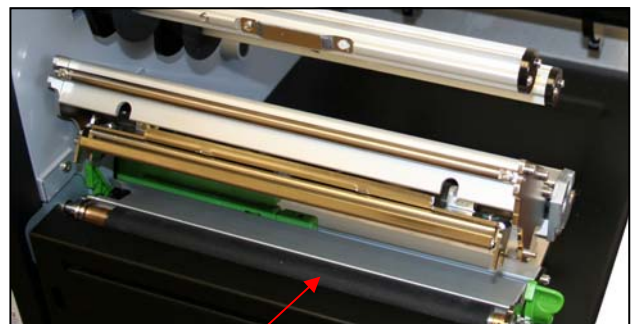

13

2.2.3 Rear View

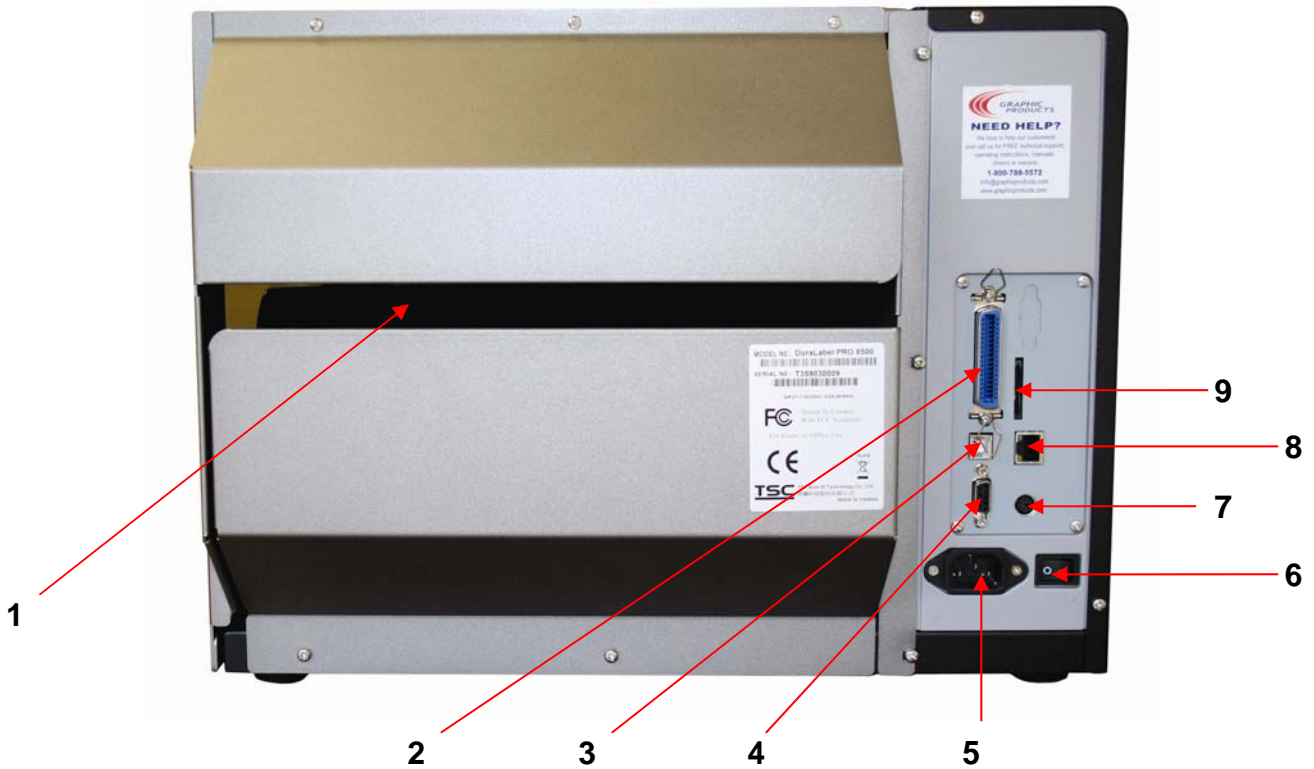

1. Fan-fold paper entrance chute
2. Parallel Port (Centronics Interface)
3. USB Interface
4. Serial Port (RS-232C Interface)
5. Power Jack Socket
6. Power Switch
7. PS/2 Interface
8. Ethernet Interface
- *9. SD Card Slot

* Recommended SD card specification.

SD V 1.0, V 1.1	SD V 2.0 (SDHC)
✓ 128MB	✓ 4GB class 6
✓ 256MB	
✓ 512MB	
✓ 1GB	
-Supported DOS FAT file system. -Folders stored on the SD card should be in the 8.3 filename format. -Approved SD card manufacturer: SanDisk, Transcend.	

2.3 Operator Controls



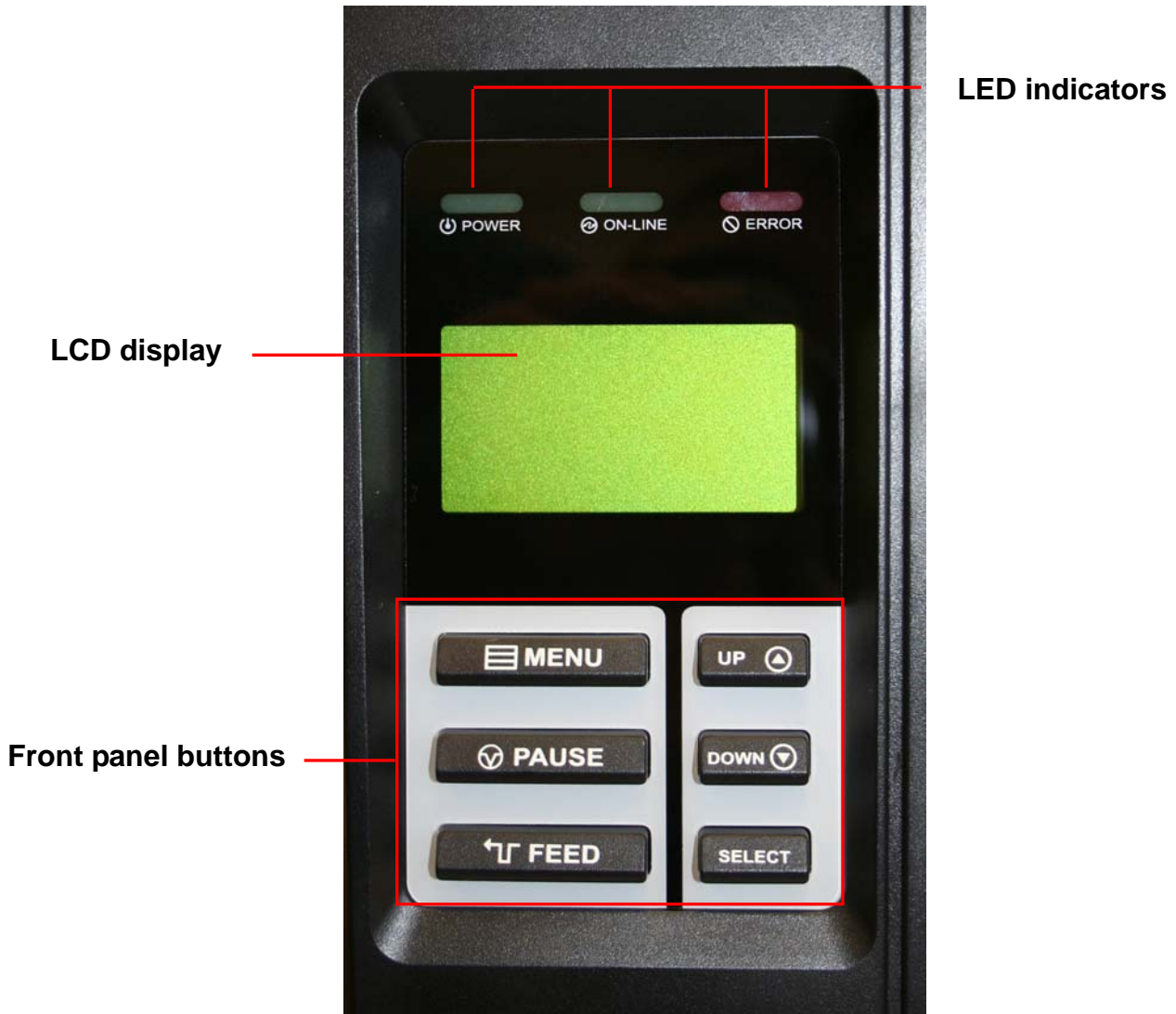

2.3.1 Front Panel Display



2.3.2 LED Indicators

LED	Status	Indication
⏻ POWER	Off	Printer power off
	On	Printer power on
🔄 ON-LINE	On	Printer is ready
	Blinking	Printer is paused
		Printer is downloading data
⊘ ERROR	Off	Printer is ready
	On	Carriage open OR cutter error
	Blinking	No paper, paper jam OR "no ribbon"

2.3.3 Front Panel Keys

Keys	Function
 MENU	1. Enter the initial menu screen 2. Once in the menu system, returns user to previous menu. If at initial menu screen, exits the menu system
 PAUSE	Pauses or resumes printing
 FEED	Advance one label
UP 	Scroll up the menu options
DOWN 	Scroll down the menu options
SELECT	Select the currently highlighted option

2.4 Setting Up the Printer

1. Place the printer on a flat, secure surface.
2. Make sure the power switch is OFF.
3. Connect the printer to the computer with the provided USB cable.
4. Plug the power cord into the AC power cord socket at the rear of the printer, and then plug the power cord into a properly grounded power outlet.

2.5 Loading Supply

1. Lift printer cover open.
2. Push the print head release lever to open the print head mechanism.

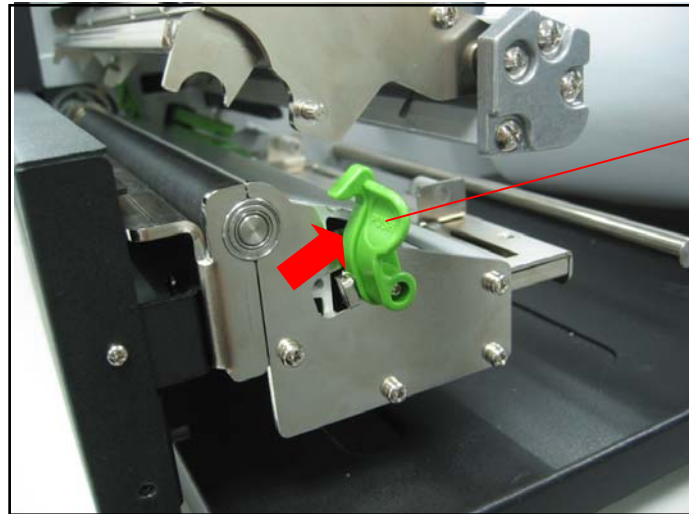

Print head
release lever

3. Remove ONE supply guide.
4. Adjust the supply guide to completely cover the numbered box that corresponds with the media width (in inches).
5. Place supply roll on supply bar.
6. Replace supply guide.



Above: Inside Supply Guide set for 6" media/supply

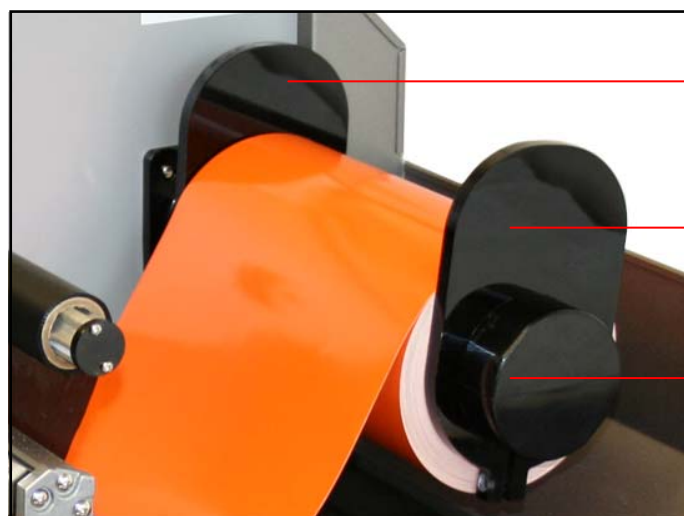

Supply
guides

Supply
bar

- Pull the leading edge of the label forward under the media guide bar, under the media sensor, and place the leading edge onto the platen roller and through the printed label opening.

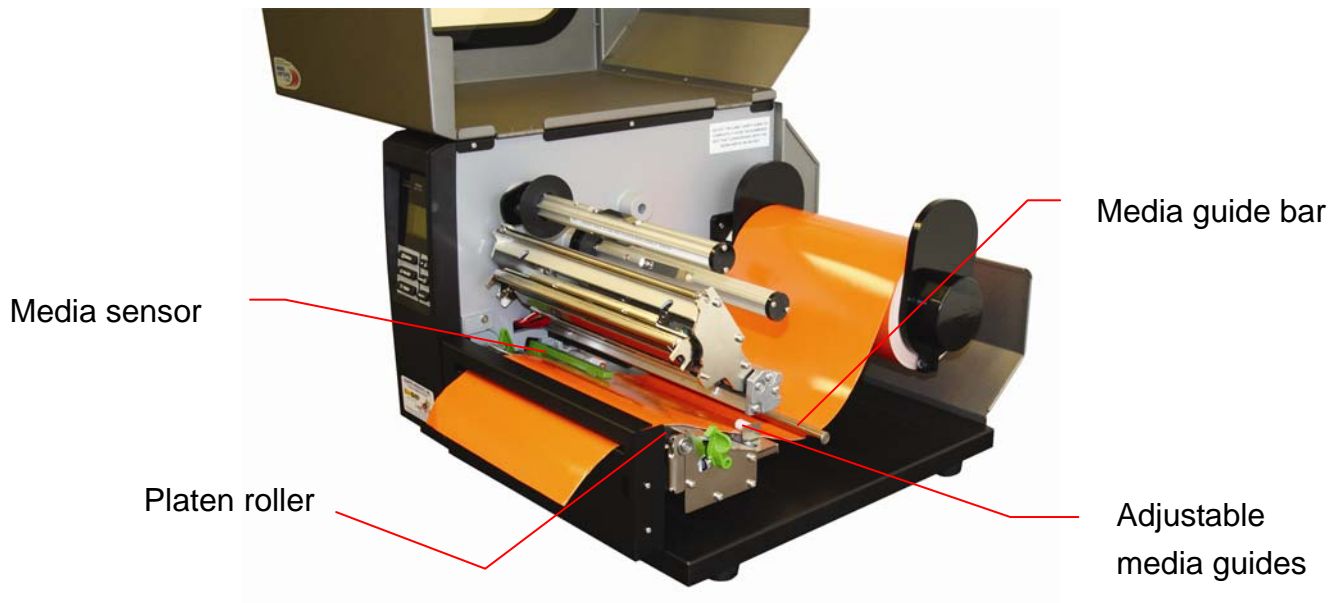

- Move the adjustable media guides to fit the supply width.
- Close print head mechanism, making sure the print head release lever latches properly.

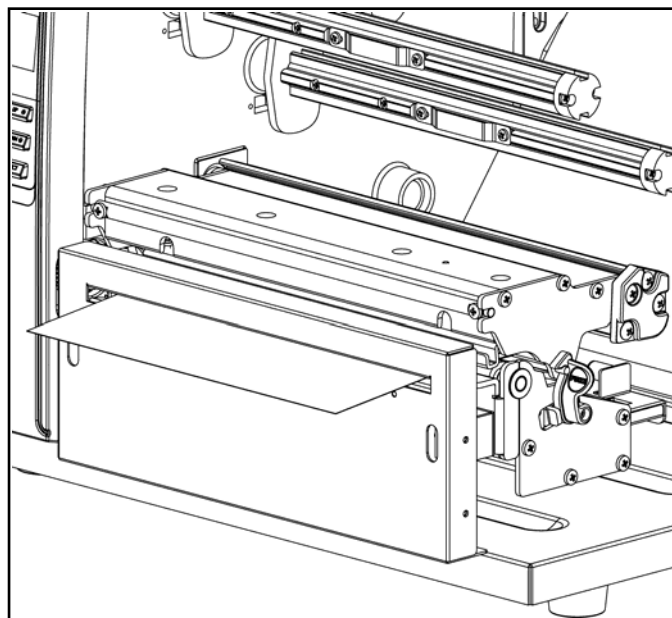

Note: When using gap/black-mark media, calibrate printer by using the front display panel.

- Loading path for label supply

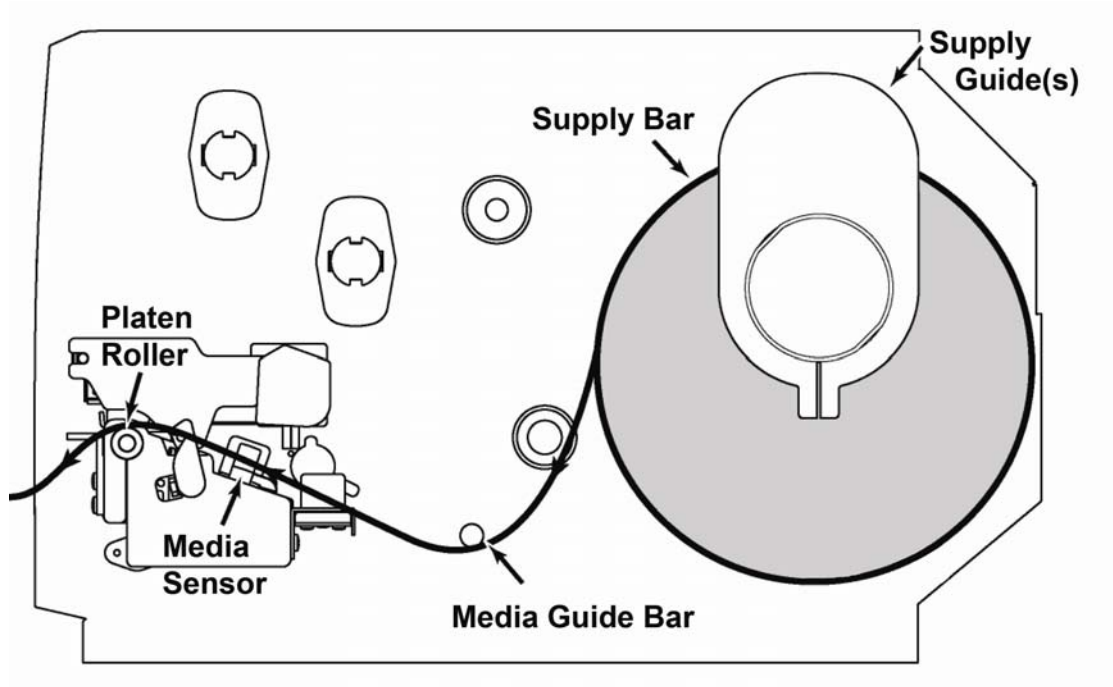

2.6 Loading Ribbon

1. Lift printer cover open.
2. Push the print head release lever to pop-up the print head mechanism.

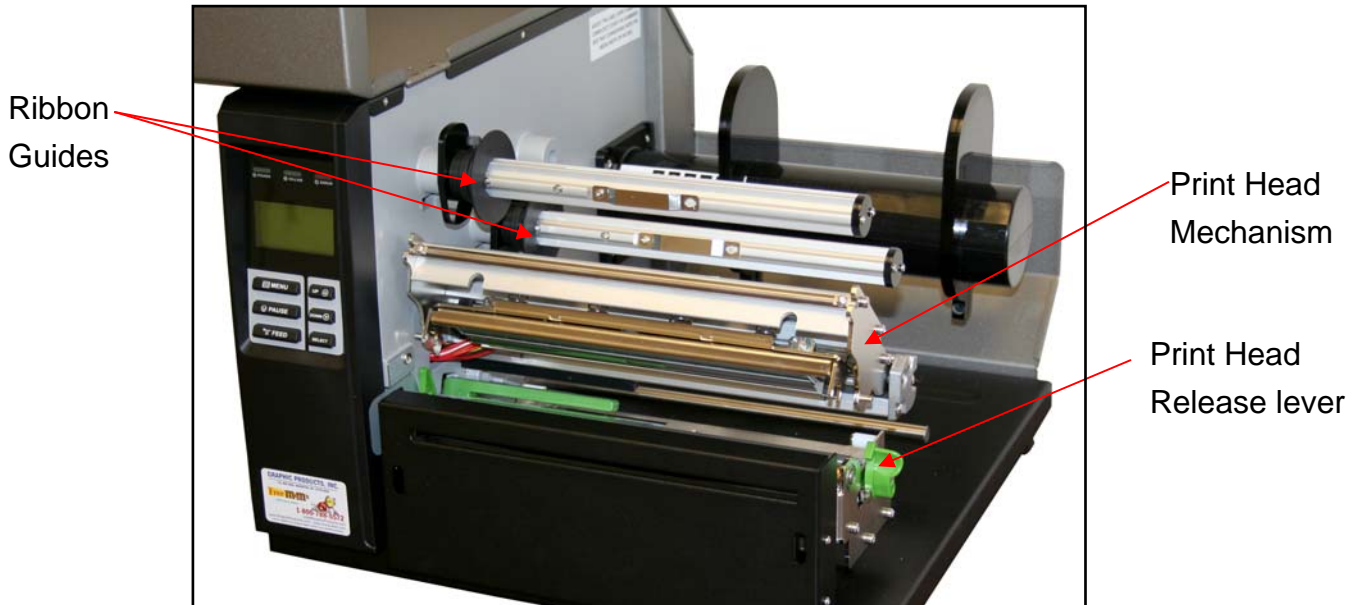

3. Adjust ribbon guides to center ribbon on vinyl.
 - When using 8.66" ribbon, adjust ribbon guides against printer wall.



- When using 4.33" ribbon, adjust ribbon guides to the line and tighten the screw.



4. Install the ribbon and empty ribbon core onto the ribbon spindle and ribbon rewind spindle.
5. Thread the ribbon underneath the print head and above the ribbon sensor.

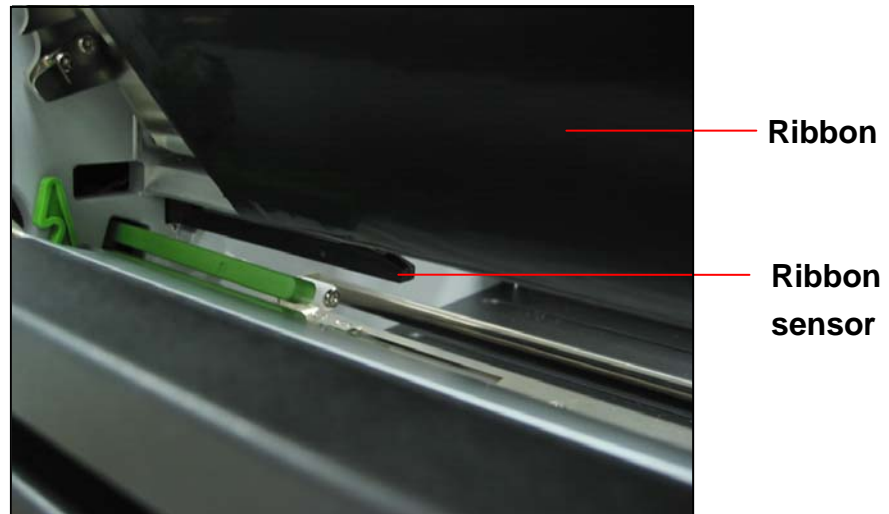

6. Apply ribbon onto empty ribbon core, keeping the ribbon flat and wrinkle-free.
7. Wind the ribbon rewind spindle clockwise roughly 3-5 times until ribbon is smooth, properly stretched and wrinkle-free.

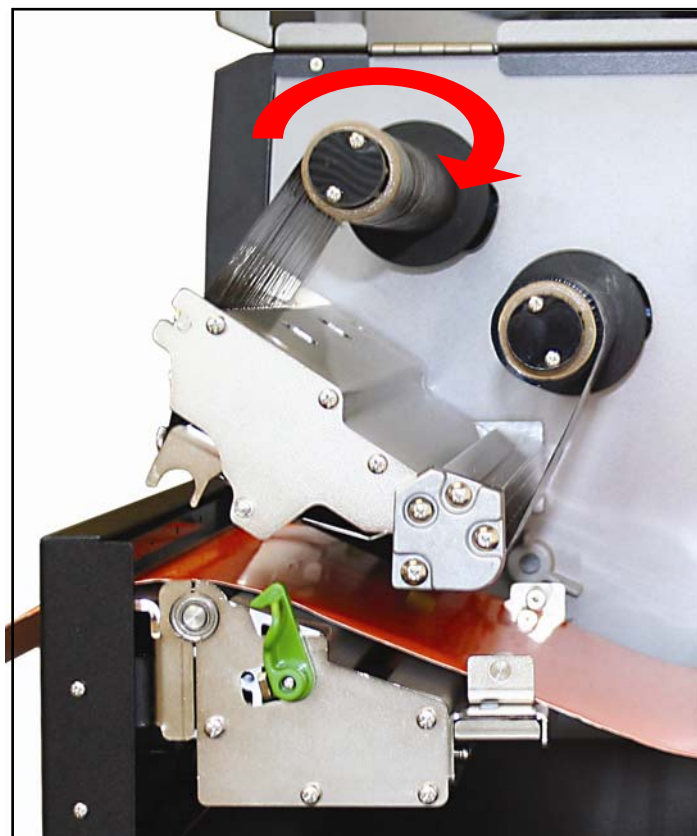

8. Close the print head mechanism, making sure the latches are engaged properly.

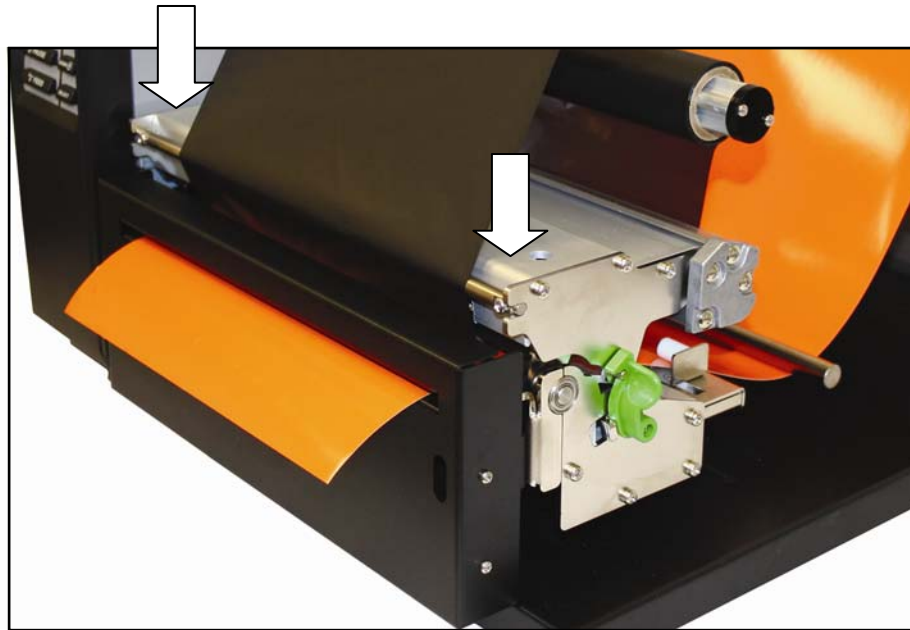

- **Loading path for ribbon**

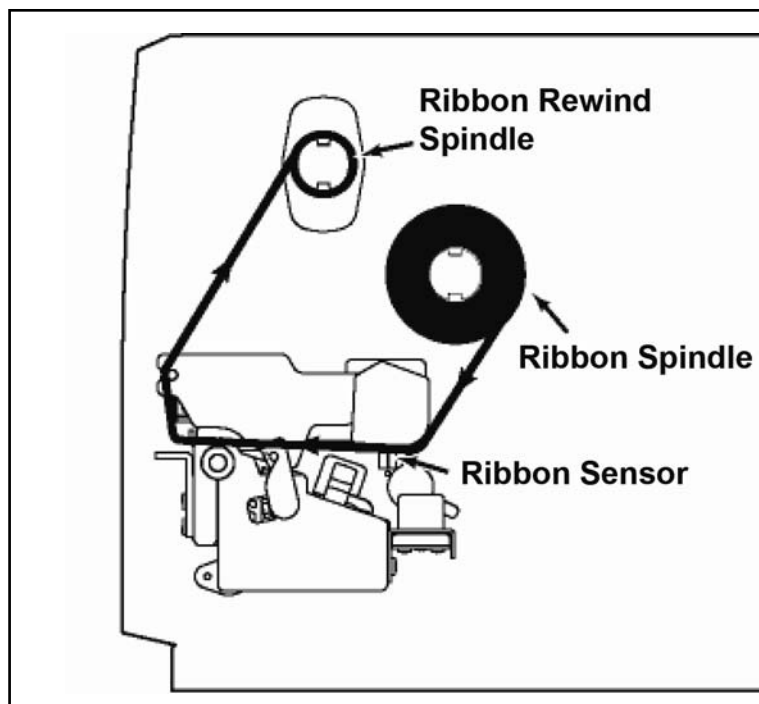

3. Menu Function

Main Menu Overview

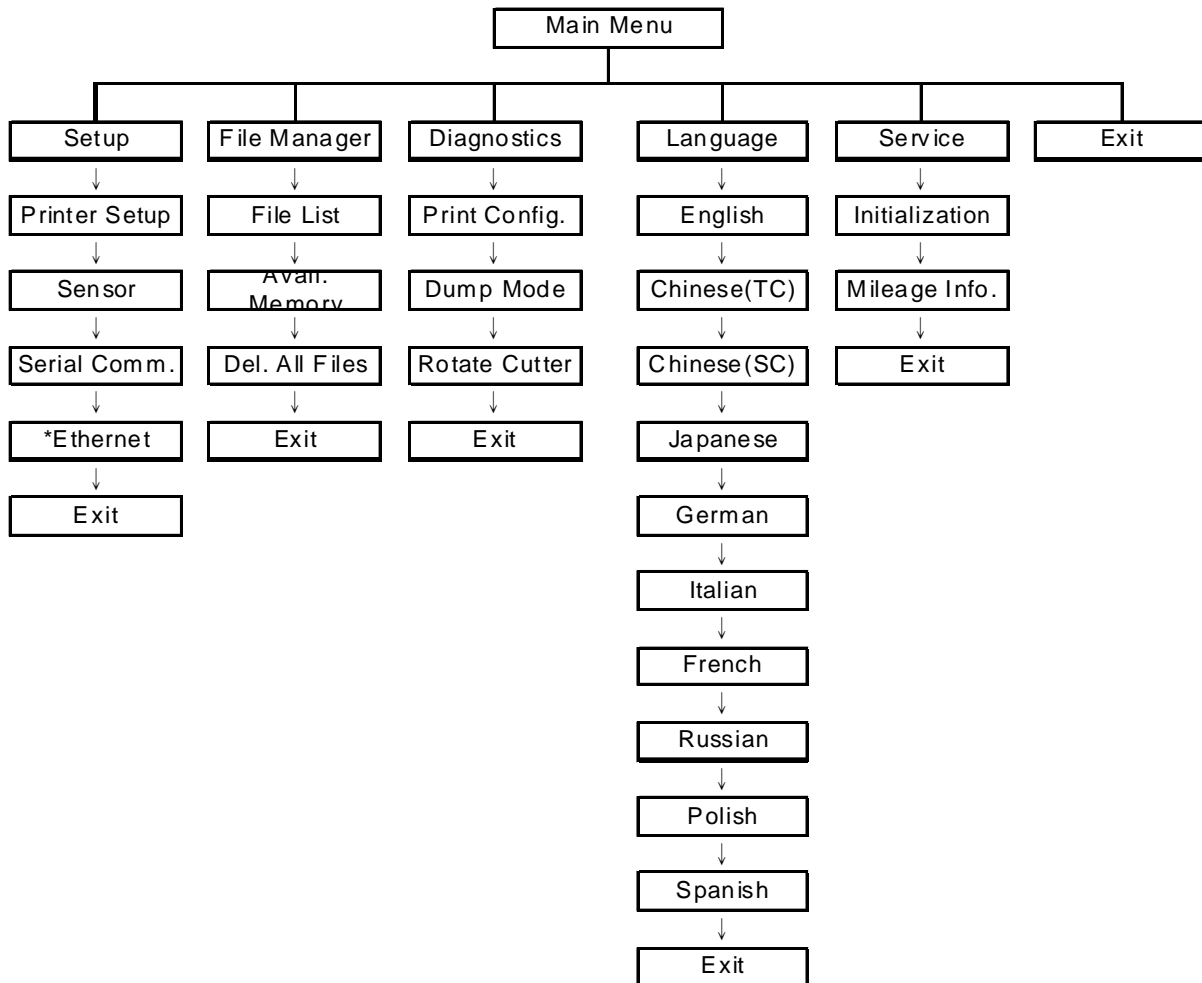

Notice:

* Ethernet function is available on the LCD display when Ethernet card is installed.

3.1 Setup Menu Overview

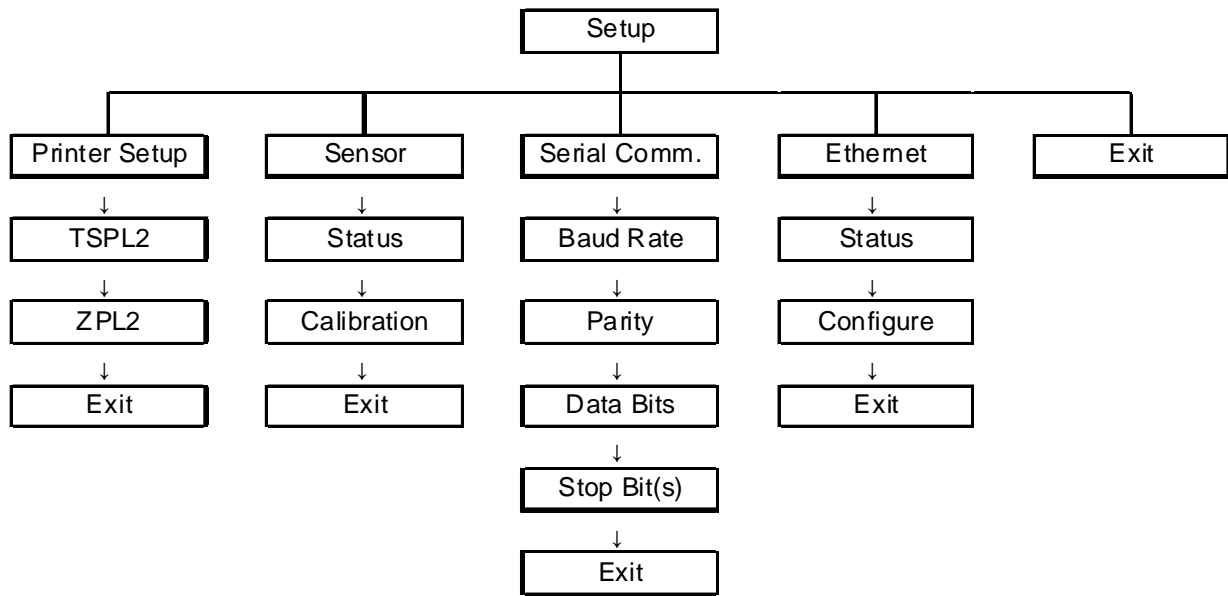

3.1.1 Printer Setup

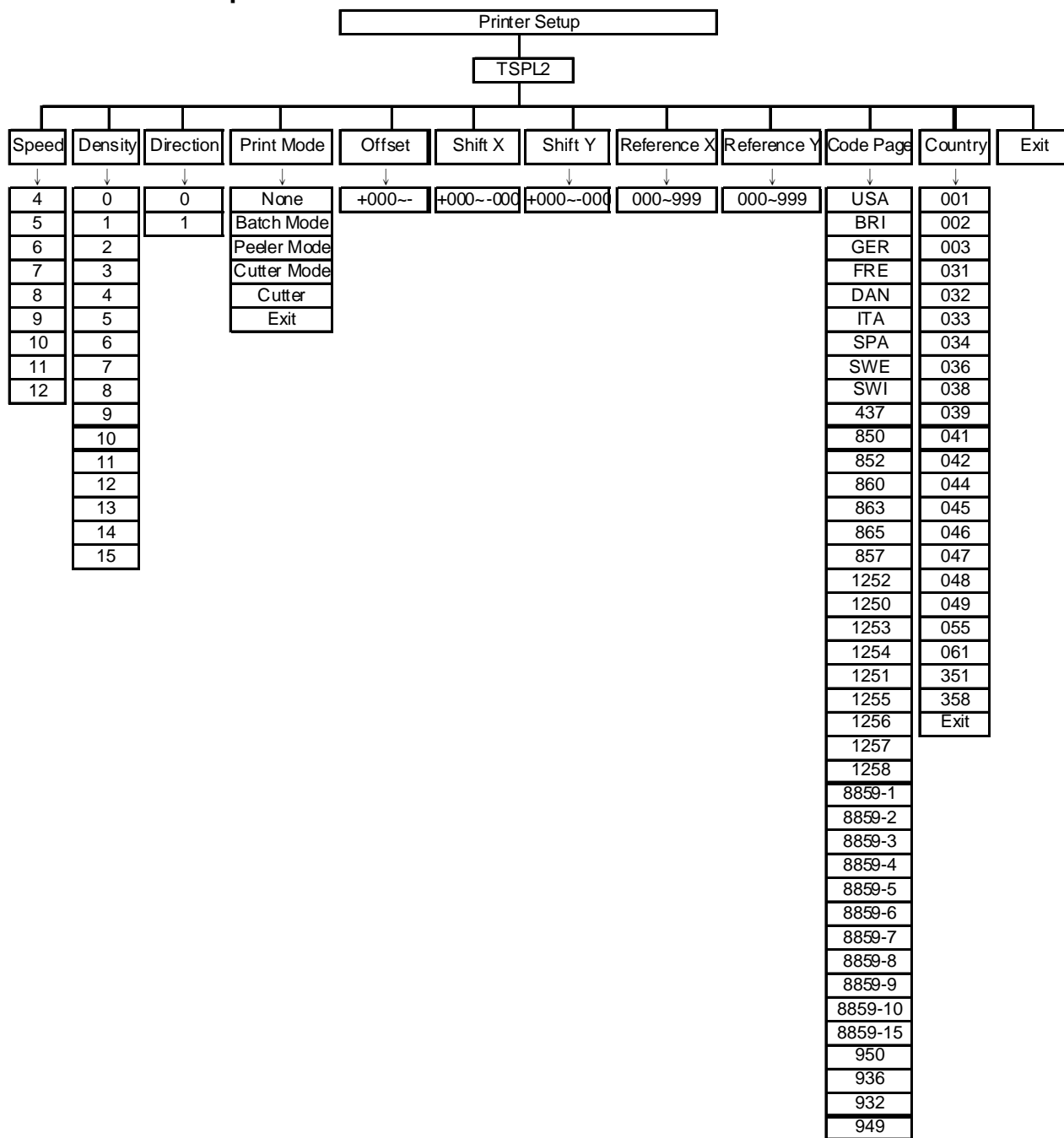

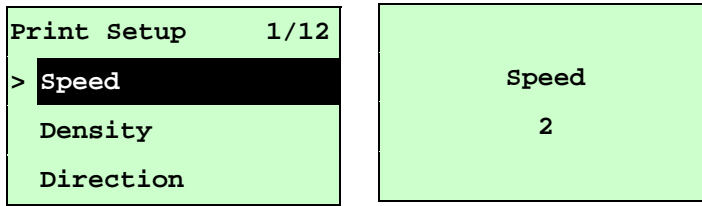

SETUP FOR PRINTING WHEN NOT CONNECTED TO A COMPUTER:

3.1.1.1 Speed:



Use this option to set print speed. The available print speed is 2 or 3 ips. The default print speed is 2 ips.



Press **UP**  key to raise the print speed, and press **DOWN**  key to decrease print speed. Press **SELECT** to accept, and press  **MENU** to cancel.

Note: If printing from enclosed software/driver, the software/driver will send out the SPEED command, which will overwrite the setting set from the front panel.

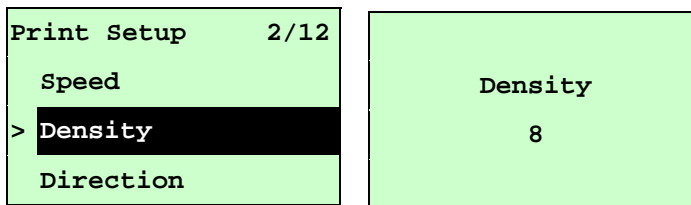
3.1.1.2 Density:



Use this option to setup printing darkness. The available setting is from 0 to 15, and the step is 1. Printer default density is 8. You may need to adjust your density based on selected media.



Press **UP**  or **DOWN**  to increase/decrease the printing darkness. Press **SELECT** to enable the setting. Press  **MENU** to cancel.

Note: If printing from enclosed software/driver, software/driver will send out DENSITY command, which overwrites the setting entered from the front panel.

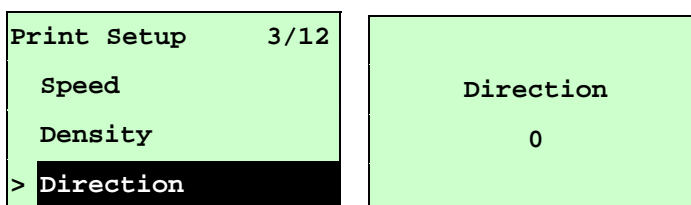
3.1.1.3 Direction:



The direction setting value is either 1 or 0. Use this option to setup the printout direction. Printer default printout direction is DIRECTION 0.

Press **UP**  key to set the direction as 1, and **DOWN**  to set it as 0, and

SELECT to enable the setting. Press **MENU** to cancel.

The following 2 figures are the printouts of DIRECTION 0 and 1 for your reference.

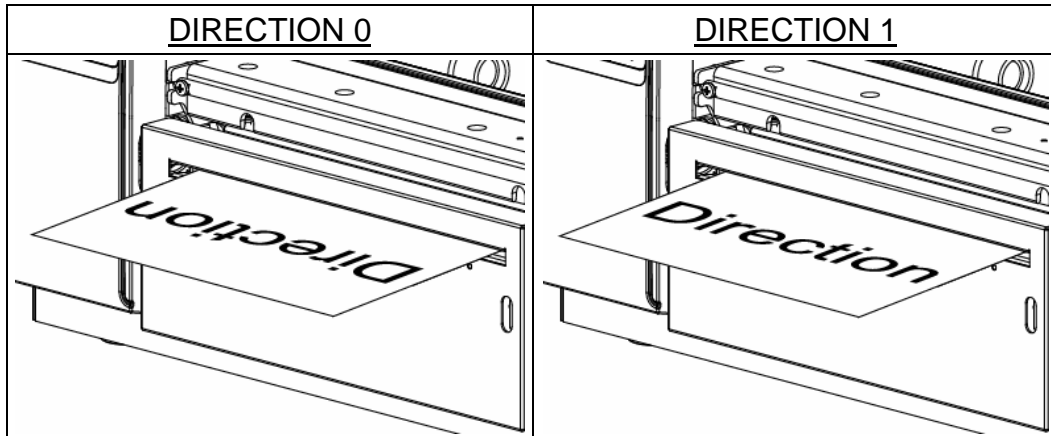

Note: If printing from enclosed software/driver, the software/driver will send out the command, which overwrites the setting entered from the front panel.

3.1.1.4 Print Mode: (None/Batch Mode/Peeler Mode/Cutter Mode/Cutter Batch)

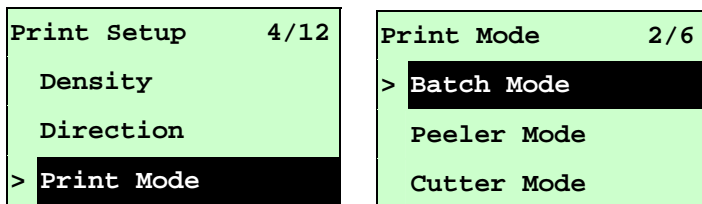

This option is used to set the print mode. Printer default setting is Batch Mode. When entering this list, the print mode in the right side of ">" icon is the printer current setting. Press **UP** or **DOWN** to select the different print mode and press **SELECT** to enable the setting. Press **MENU** to cancel.

Printer Mode	Description
None	Next label is aligned to the print head burn line location. (Tear Off Mode)
Batch Mode	Once image is printed completely, label gap/black-mark will be fed to the tear plate location for tear away.
Peeler Mode	Enable the label peel off mode.
Cutter Mode	Enable the label cutter mode.
Cutter Batch	Cut the label once at the end of the printing job.

Note: If printing from enclosed software/driver, the software/driver will send out the command, which overwrites the setting set from the front panel.

3.1.1.5 Offset:

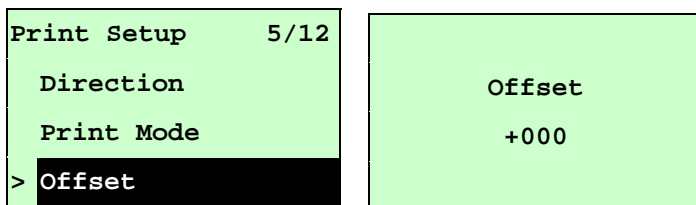

This option is used to fine tune media stop location. Press **DOWN** to move the cursor from left digit to right digit, and press **UP** to set the value from “+” to “-” or “0” to “9”. Press **SELECT** to set the value into printer. Press **MENU** to cancel. The default value is +000.

Note: If printing from enclosed software/driver, the software/driver will send out the OFFSET command, which will overwrite the setting set from the front panel.

3.1.1.6 Shift X & Shift Y:

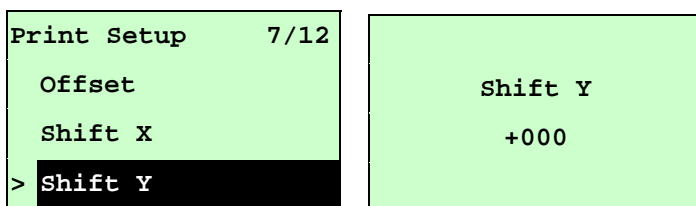

This option is used to fine tune print position. Press **DOWN** to move the cursor from left to right, and press **UP** to set the value from “+” to “-” or “0” to “9”. Press **SELECT** to set the value into printer. Press **MENU** to cancel. The default value is +000.

Note: If printing from enclosed software/driver, the software/driver will send out the SHIFT command, which will overwrite the setting set from the front panel.

3.1.1.6 Reference X & Reference Y:

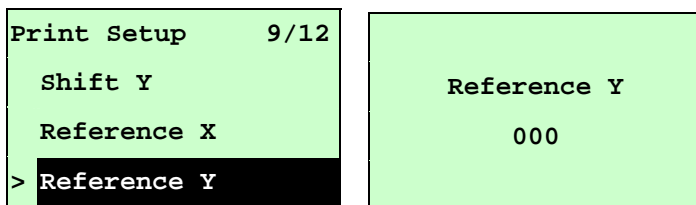

This option is used to set the origin of printer coordinate system horizontally and vertically. Press **DOWN** to move the cursor from left digit to right digit, and press **UP** button to set the value from “0” to “9”. Press the **SELECT** button to set the value into printer. Press **MENU** key to cancel the setting and return to the

previous menu. The default value is 000.

Note: If printing from enclosed software/driver, the software/driver will send out the REFERENCE command, which will overwrite the setting entered from the front panel.

3.1.1.7 Code Page:

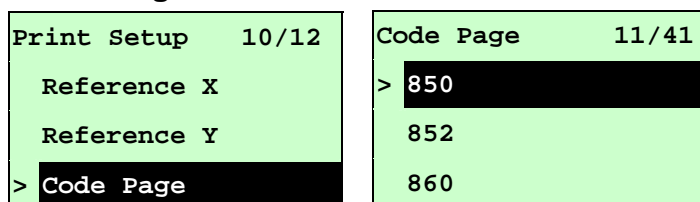

Use this option to set the code page of international character set. For more information about code page, call Graphic Products at 1-800-788-5572.

When entering the code page list, the code page in the right side of ">" icon is the printer current setting.

Press **UP** or **DOWN** to select the code page, and press **SELECT** to enable the setting. Press **MENU** to cancel.

Note: If printing from enclosed software/driver, the software/driver will send out the command, which overwrites the setting entered from the front panel.

7-bit		8-bit	
code page name	International Character Set	code page number	International Character Set
USA	USA	437	United States
BRI	British	850	Multilingual
GER	German	852	Slavic
FRE	French	860	Portuguese
DAN	Danish	863	Canadian/French
ITA	Italian	865	Nordic
SPA	Spanish		
SWE	Swedish		
SWI	Swiss		

Windows Code Page (SBCS)		Windows Code Page (DBCS)	
code page number	International Character Set	code page number	International Character Set
1252	Latin 1	950	Traditional Chinese Big5
1250	Central Europe	936	Simplified Chinese GBK
1253	Greek	932	Japanese Shift-JIS
1254	Turkish	949	Korean

1251	Cyrillic		
1255	Hebrew		
1256	Arabic		
1257	Baltic		
1258	Vietnam		

ISO Code Page		ISO Code Page	
code page name	International Character Set	code page number	International Character Set
8859-1	Latin 1	8859-7	Greek
8859-2	Latin 2	8859-9	Turkish
8859-3	Latin 3	8859-10	Latin 6
8859-4	Baltic	8859-15	Latin 9
8859-5	Cyrillic		

3.1.1.8 Country:

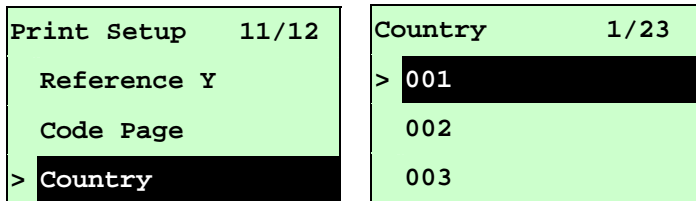

Use this option to set the country code for the LCD display. Press the **UP** and **DOWN** to select the country code, and press the **SELECT** button to set the value into printer. When enter this list, the country code in the right side of ">" icon is the printer current setting. Press **MENU** key to cancel the setting and return to the previous menu.

Code	Country	Code	Country	Code	Country	Code	Country
001	USA	034	Spanish (Spain)	044	United Kingdom	055	Brazil
002	Canadian-French	036	Hungarian	045	Danish	061	English (International)
003	Spanish (Latin America)	038	Yugoslavian	046	Swedish	351	Portuguese
031	Dutch	039	Italian	047	Norwegian	358	Finnish
032	Belgian	041	Switzerland	048	Polish		
033	French (France)	042	Slovak	049	German		

3.1.2 Sensor

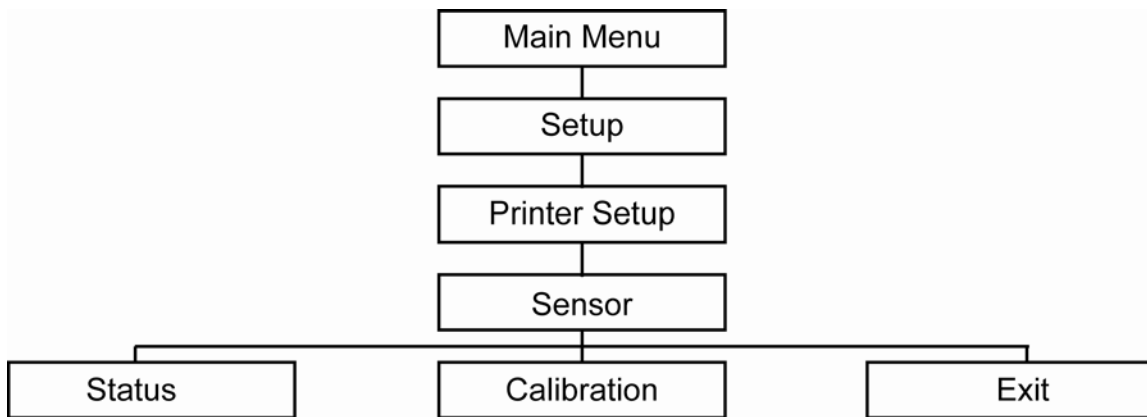

3.1.2.1 Status

This function is available to check the printer's sensor status.

Paper Len.	812
Gap Size	24
Intensity	3
Ref. Level	512

3.1.2.2 Calibration

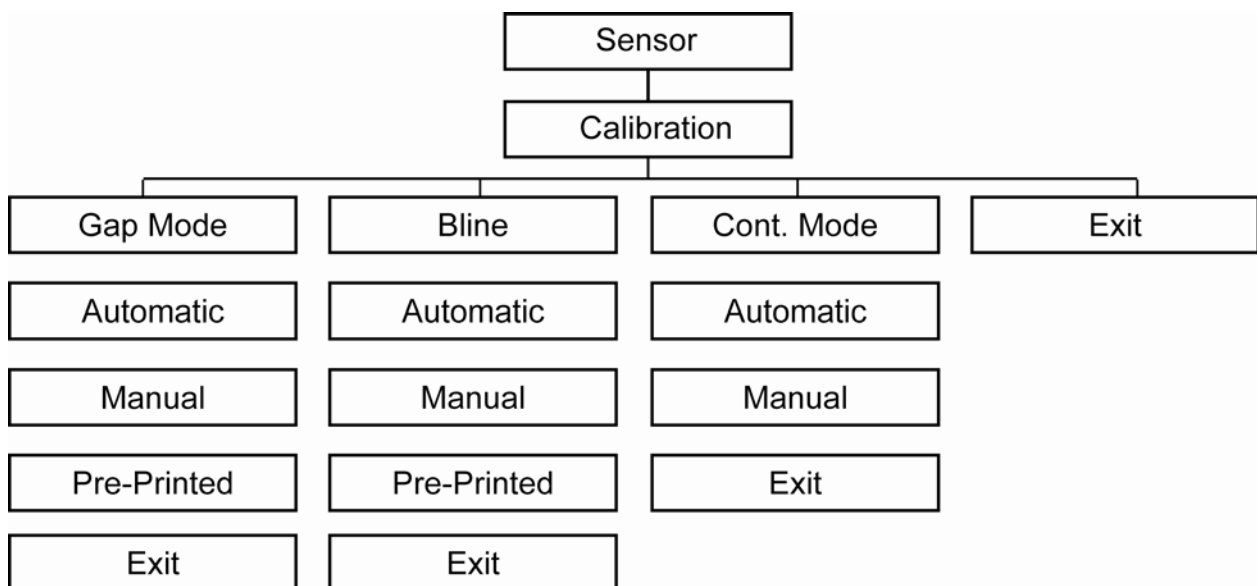

This option is used to set the media sensor type and calibrate the selected sensor. We recommend calibrating the sensor before printing when changing the supply type.

From the Sensor menu, follow this tree:

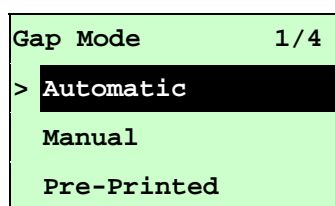
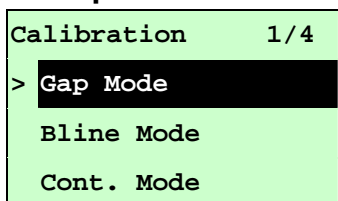

A. Gap Mode



Press the **UP**  or **DOWN**  to move the cursor to the media type and press **SELECT** to enter the sensor calibration mode.

Note: *If printing from enclosed software/driver, the software/driver will send out the GAP or BLINE command, which will overwrite the sensor type setting set from the front panel.*

A-1 Automatic

When you enter the [Automatic] option, you will see following message, and the printer will feed 2 to 3 gap labels to calibrate the sensor sensitivity automatically. When calibration is completed, the LCD screen will return to the previous menu.

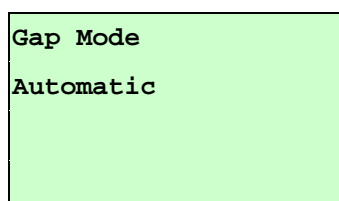

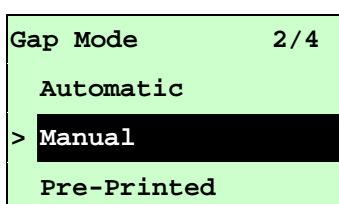

A-2 Manual

If “Automatic” sensor calibration is unable to adjust the supply, please use “Manual” function to calibrate the gap sensor manually.

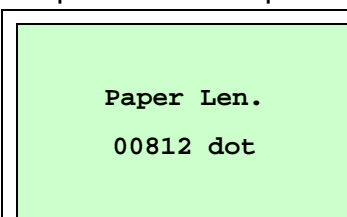

When you enter the [Manual] option, you will see following message. Please complete these steps:



1. Press **DOWN**  to move the cursor from left digit to right digit, and press **UP**  to set the value from “0” to “9” and the “dot/ mm/ inch”. Press **SELECT** to set the paper length into the printer.

<p style="text-align: center;">Gap Size 0024 dot</p>	<p>2. Press DOWN ⬇️ to move the cursor from left digit to right digit, and press UP ⬆️ to set the value from “0” to “9” and the “dot/ mm/ inch”. Press SELECT to set the gap size into the printer.</p>
<p>Gap Mode Scan Backing Intensity x Ref. Level xxx</p>	<p>3. Open the print head mechanism and put the label backing (liner) under the media sensor. Press SELECT to set the value into the printer.</p>
<p>Gap Mode Scan Paper Intensity x Ref. Level xxx</p>	<p>4. Then, put the label with liner under the media sensor. Press SELECT to set the value into the printer.</p>
<p>Gap Mode Complete Intensity x Ref. Level xxx</p>	<p>5. The gap sensor calibration is complete. Press SELECT; the LCD screen will return to the previous menu.</p>

A-3 Pre-Printed

This function can set the paper length and gap size prior to auto-calibration of the sensor sensitivity. It will set the sensor sensitivity accurately.

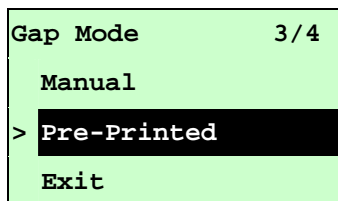

When entering [Pre-Printed] option, you will see following message. Please complete these steps:

<p style="text-align: center;">Paper Len. 00812 dot</p>	<p>1. Press DOWN ⬇️ to move the cursor from left digit to right digit, and press UP ⬆️ button to set the value from “0” to “9” and the “dot/ mm/ inch”. Press SELECT to set the paper length into the printer.</p>
<p style="text-align: center;">Gap Size 0024 dot</p>	<p>2. Press DOWN ⬇️ to move the cursor from left digit to right digit, and press UP ⬆️ to set the value from “0” to “9” and the “dot/ mm/ inch”. Press SELECT to set the gap size into the printer.</p>

Gap Mode
Pre-Printed

3. The printer will feed labels to calibrate the sensor sensitivity automatically. When calibration is completed, the LCD screen will return to the previous menu.

B. Bline Mode (also known as Black-Mark Mode, or labels with marks)

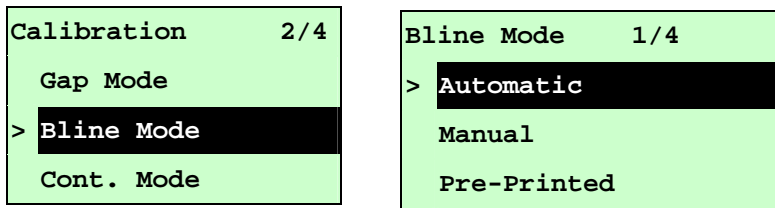

Press **UP** ⤴ and **DOWN** ⤵ to scroll the cursor to the sensor type. Press **SELECT** to enter the black-mark sensor calibration mode.

B-1 Automatic

When you enter the [Automatic] option, you will see following message and the printer will feed the black-mark label to calibrate the sensor sensitivity automatically. When calibration process is completed, the LCD screen will return to the previous menu.

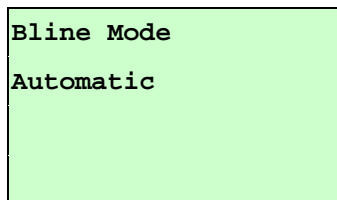

B-2 Manual

In case “Automatic” sensor calibration cannot apply to the media, use “Manual” function to calibrate the bline sensor manually.

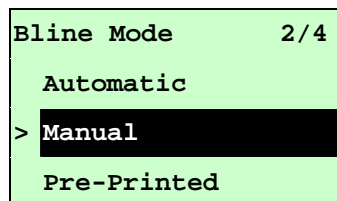

When entering the [Manual] option, you will see following message. Please complete these steps:

<p>The screenshot shows the LCD screen with the text 'Paper Len.' on the top line and '00151 dot' on the bottom line.</p>	<p>1. Press DOWN ⤵ to move the cursor from left digit to right digit, and press UP ⤴ to set the value from “0” to “9” and the “dot/ mm/ inch”. Press SELECT to set the paper length into the printer.</p>
<p>The screenshot shows the LCD screen with the text 'Bline Size' on the top line and '0024 dot' on the bottom line.</p>	<p>2. Press DOWN ⤵ to move the cursor from left digit to right digit, and press UP ⤴ to set the value from “0” to “9” and the “dot/ mm/ inch”. Press SELECT to set the bline size into the printer.</p>

<pre> Bline Mode Scan Mark Intensity x Ref. Level xxx </pre>	<p>3. Open the print head mechanism, put the black-mark under the media sensor. Press SELECT to set the value into the printer.</p>
<pre> Bline Mode Scan Paper Intensity x Ref. Level xxx </pre>	<p>4. Then, put the label without black-mark under the media sensor. Press SELECT to set the value into the printer.</p>
<p>Note: Normally, the value of "Ref. Level" for mark should be larger than paper for over 128. If the media sensor fails to do so, you have to manually change the Intensity by pressing UP ⬆ or DOWN ⬇ to reach the above value.</p>	
<pre> Bline Mode Complete Intensity x Ref. Level xxx </pre>	<p>5. The bline sensor calibration is complete. Press SELECT; the LCD screen will return to the previous menu.</p>

B-3 Pre-Printed

This function can set the paper length and gap size before auto-calibrating the sensor sensitivity.

<pre> Bline Mode 3/4 Manual > Pre-Printed Exit </pre>

When enter [Pre-Printed] option, you will see following message. Please complete these steps:

<pre> Paper Len. 00812 dot </pre>	<p>1. Press the DOWN ⬇ button to move the cursor from left digit to right digit, and press the UP ⬆ button to set the value from "0" to "9" and the "dot/mm/ inch". Press the SELECT button to set the paper length into the printer.</p>
<pre> Bline Size 0024 dot </pre>	<p>2. Press the DOWN ⬇ button to move the cursor from left digit to right digit, and press the UP ⬆ button to set the value from "0" to "9" and the "dot/mm/ inch". Press the SELECT button to set the bline size into the printer.</p>

Bline Mode
Pre-Printed

3. Printer will feed labels to calibrate the sensor sensitivity automatically. When calibration is completed, the LCD screen will return to the previous menu.

C. Cont. Mode

```
Calibration      3/4
  Bline Mode
> Cont. Mode
  Exit
```

```
Cont. Mode      1/3
> Automatic
  Manual
  Exit
```

Press **UP** \odot or **DOWN** \ominus to scroll the cursor to the sensor type. Press **SELECT** to enter the black-mark sensor calibration mode.

C-1 Automatic

When entering the [Automatic] option, you will see following message and the printer will calibrate the sensor sensitivity automatically. When calibration process is completed, the LCD screen will return to the previous menu.

```
Cont. Mode
Automatic
```

C-2 Manual

In case “Automatic” sensor calibration cannot apply to the media, use “Manual” function to calibrate the sensor manually.

```
Cont. Mode      2/3
  Automatic
> Manual
  Exit
```

When you enter [Manual] option, you will see following message. Please complete these three steps:

<pre>Cont. Mode Remove Label Intensity x Ref. Level xxx</pre>	1. Remove the label supply. Press SELECT to set the value into the printer.
<pre>Cont. Mode Scan Paper Intensity x Ref. Level xxx</pre>	2. Put the label supply under the media sensor. Press SELECT to set the value into the printer.

Cont. Mode Complete Intensity x Ref. Level xxx	3. The sensor calibration is complete. Press SELECT ; the LCD screen will return to the previous menu.
---	--

3.1.3 Serial Comm.

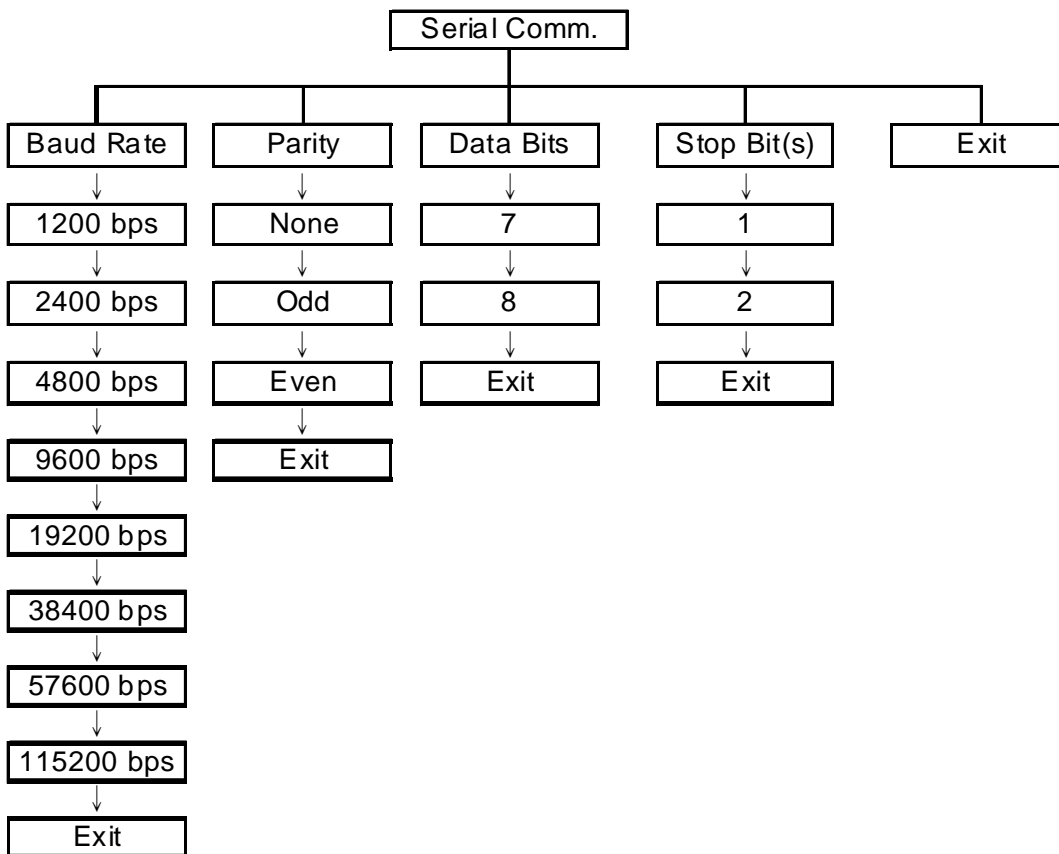

3.1.3.1 Baud Rate

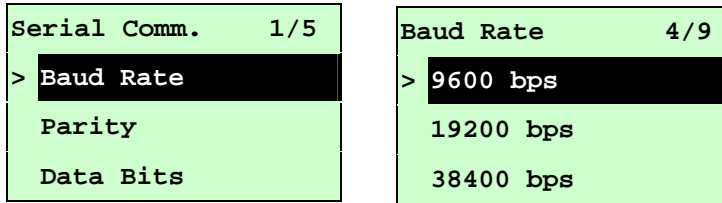

This option is used to set the RS-232 baud rate. The default setting is 9600 bps. Press **UP** ⤴ or **DOWN** ⤵ to select the different baud rate and press **SELECT** to set the value into the printer. When you enter this list, the baud rate value in the right side of ">" icon is the current setting in the printer. Press **MENU** to cancel.

3.1.3.2 Parity

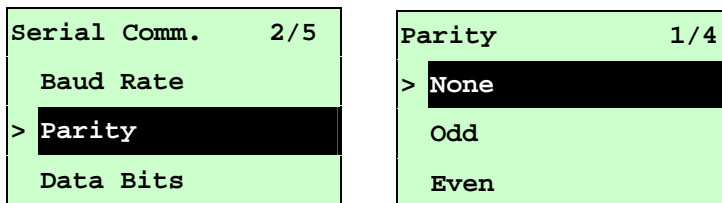

This option is used to set the RS-232 parity. The default setting is "None". Press **UP** ⤴ or **DOWN** ⤵ to select the different parity and press **SELECT** to set the value into the printer. When you enter this list, the parity in the right side of ">" is the printer current setting. Press **MENU** to cancel.

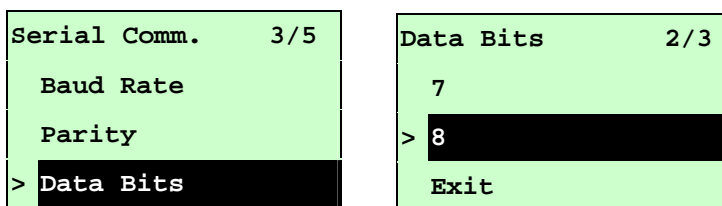

3.1.3.3 Data Bits:

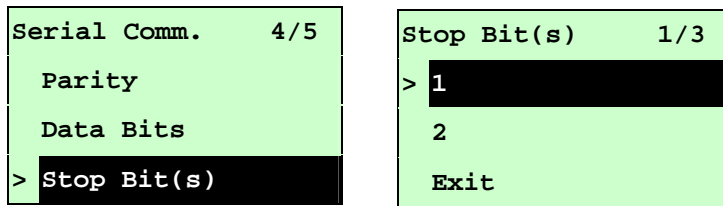

This option is used to set the RS-232 Data Bits. The default setting is "8" data bits. Press **UP** ⤴ or **DOWN** ⤵ to select the different Data Bits and press **SELECT** to set the value into the printer. When you enter this list, the Data Bits in the right side of ">" icon is the printer current setting. Press **MENU** to cancel.

3.1.3.4 Stop Bit(s):



This option is used to set the RS-232 Stop Bits. The default setting is “1” stop bit. Press **UP**  or **DOWN**  to select the different Stop Bits and press **SELECT** to set the value into the printer. When you enter this list, the option in the right side of ">" icon is the printer current setting. Press  **MENU** to cancel.

3.1.4 Ethernet

Use this menu to configure internal Ethernet, check the printer's Ethernet module status, and reset the Ethernet module. This function is available on the LCD display when an Ethernet card is installed.

Press **UP** ⬆ or **DOWN** ⬇ to select the different options and press **SELECT** to enter the option. Press **MENU** to cancel the setting and return to the previous menu.

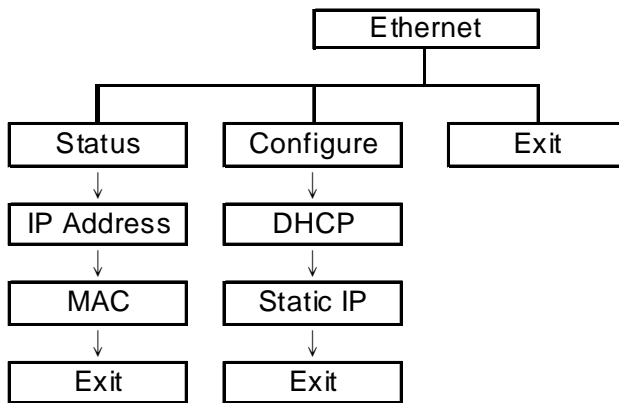

3.1.4.1 Status: (IP Address / MAC)

Use this menu to check the Ethernet setting status.

3.1.4.1.1 IP Address

```
Ethernet 1/3
> Status
Configure
Exit
```

```
Status 1/3
> IP Address
MAC
Exit
```

```
IP Address
0.0.0.0
Subnet Mask
0.0.0.0
Gateway
0.0.0.0
```

The IP address information will be shown on the LCD display. Please press **SELECT** or **MENU** to return to the previous menu.

3.1.4.1.2 MAC

```
Ethernet 1/3
> Status
Configure
Exit
```

```
Status 2/3
IP Address
> MAC
Exit
```

```
MAC Address
001B82-FF0918
```

The MAC address information will be shown on the LCD display. Please press **SELECT** or **MENU** to return to the previous menu.

3.1.4.2 Configure: (DHCP / Static IP)

Use this menu to set the printer's DHCP and Static IP.

3.1.4.2.1 DHCP

```
Ethernet 2/4
Status
> Configure
Reset
```

```
Configure 1/3
> DHCP
Static IP
Exit
```

Press **UP** \odot or **DOWN** \odot to select the DHCP function and press **SELECT** to enter. Press **MENU** to cancel the setting and return to the previous menu.

```
DHCP

SELECT: YES
MENU: NO
```

Press **SELECT** the printer will set DHCP and restart to reset the setting. Press **MENU** to return to the previous menu.

3.1.4.2.2 Static IP

Use this menu to set the printer's IP address, subnet mask and gateway.

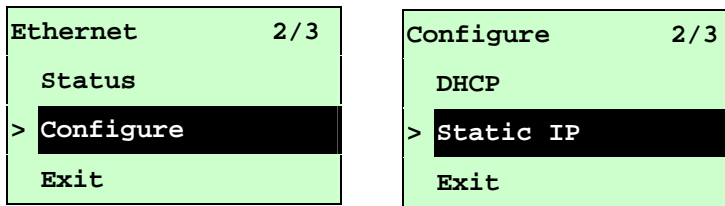

Press **UP** ⤴ or **DOWN** ⤵ to select the different options and press **SELECT** to enter the option. Press **MENU** to cancel.

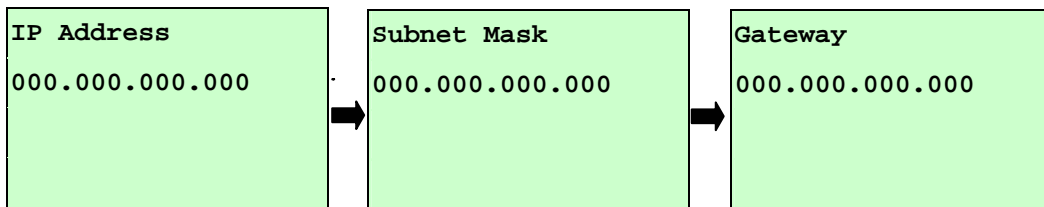

Press **DOWN** ⤵ to move the cursor from left to right digits and press the **UP** ⤴ to scroll the value from "0" to "9". Press **SELECT** to move to the next setting.

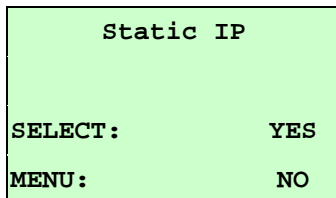

Press **SELECT**. Printer will restart to reset the Ethernet module setting. Press **MENU** key to cancel the setting.

3.2 File Manager

This feature is used to check the printer's available memory and file list.

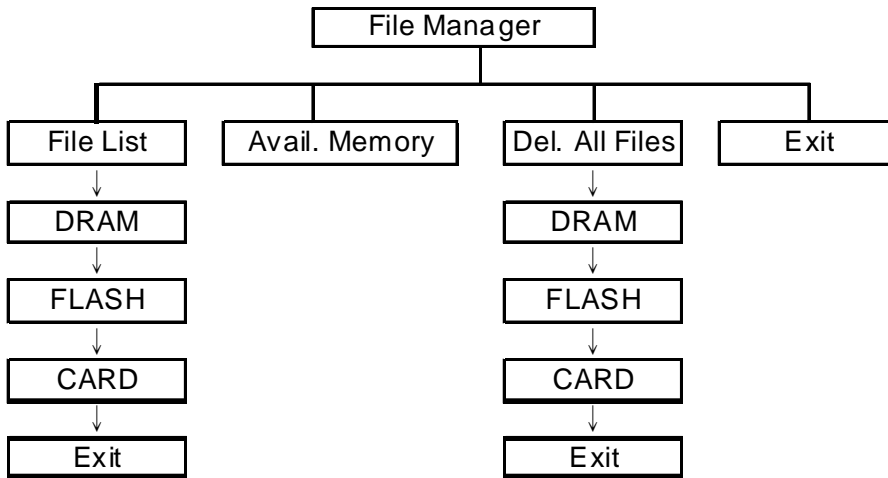

3.2.1 File List

Use this menu to show, delete and run (.BAS) the files saved in the printer DRAM/Flash/Card memory.

To show the files :

```

File Manager 1/4
> File List
  Avail. Memory
  Del. All Files
  
```

```

File List 2/4
> FLASH
  CARD
  Exit
  
```

```

FLASH File List
> DEMO.TTF
  DEMO.BAS
  
```

To delete the file, please follow the order to press **DOWN** Ⓞ.

```

FLASH File List
> DEMO.TTF
  DEMO.BAS
  
```

```

DEMO.TTF
1.75 MB
DOWN: Delete
  
```

To run the file (.BAS), please follow the order to press **SELECT** .

```

FLASH File List
  DEMO.TTF
> DEMO.BAS
  
```

```

DEMO.BAS
406 Byte(S)
DOWN: Delete
SELECT: Run
  
```

3.2.2 Avail. Memory

Use this menu to show available memory space.

File Manager 2/4	Avail. Memory
File List	DRAM: 256 KB
> Avail. Memory	FALSH: 6656 KB
Del. All Files	CARD: 0 KB

3.2.3 Del. All Files

Use this menu to delete all files. Press **SELECT** to delete all files in the device. Press **MENU** to cancel deleting files and go back to previous menu.

File Manager 3/4	File List 1/4	Del. All Files
File List	> DRAM	
Avail. Memory	FALSH	SELECT: YES
> Del. All File	CARD	MENU: NO

3.3.2 Dump Mode

Captures the data from the communications port and prints out the data received by the printer. In the dump mode, all characters will be printed in 2 columns as following. The left side characters are received from your system and right side data are the corresponding hexadecimal value of the characters. It allows users to verify and debug the program.

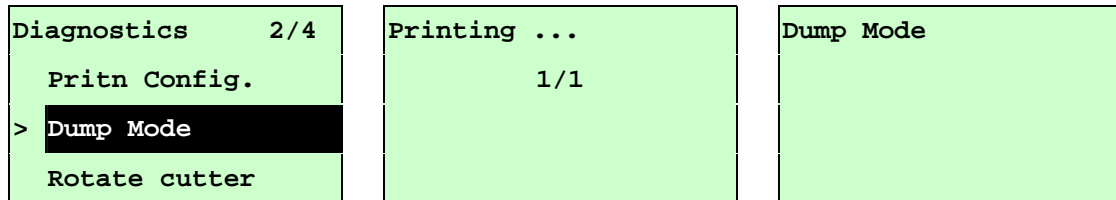

Note:

- 1. Dump mode requires 4" wide paper width.**
- 2. Turn off / on the power to resume printer for normal printing.**
- 3. Press FEED button to back to the previous menu.**

```
DOWNLO 0D 0A 44 4F 57 4E 4C 4F 4I
D "TEST2. 44 20 22 54 45 53 54 32 2E
DAT",5,CL 44 41 54 22 2C 35 2C 43 4C
S DOWNLO 53 0D 0A 44 4F 57 4E 4C 4F
AD F,"TES 41 44 20 46 2C 22 54 45 53
T4.DAT",5 54 34 2E 44 41 54 22 2C 35
,CLS DOW 2C 43 4C 53 0D 0A 44 4F 57
NLOAD "TE 4E 4C 4F 41 44 20 22 54 45
ST2.DAT", 53 54 32 2E 44 41 54 22 2C
5,CLS DO 35 2C 43 4C 53 0D 0A 44 4F
WNLOAD F, 57 4E 4C 4F 41 44 20 46 2C
"TEST4.DA 22 54 45 53 54 34 2E 44 41
T",5,CLS 54 22 2C 35 2C 43 4C 53 0D
DOWNLOAD 0A 44 4F 57 4E 4C 4F 41 44
"TEST2.D 20 22 54 45 53 54 32 2E 44
AT",5,CLS 41 54 22 2C 35 2C 43 4C 53
DOWNLOA 0D 0A 44 4F 57 4E 4C 4F 4I
D F,"TEST 44 20 46 2C 22 54 45 53 54
4.DAT",5, 34 2E 44 41 54 22 2C 35 2C
CLS 43 4C 53 0D 0A
```

ASCII Data

Hexadecimal data related to left column of ASCII data

3.3.3 Rotate Cutter

In case paper is jammed in the cutter, this feature can rotate the cutter blade forward or reverse direction, which is helpful to remove the jammed paper easily from the cutter.

Diagnosics 3/4	UP: Fwd.
Print Config.	DOWN: Rev.
Dump Mode	
> Rotate Cutter	MENU: Exit

3.4 Language

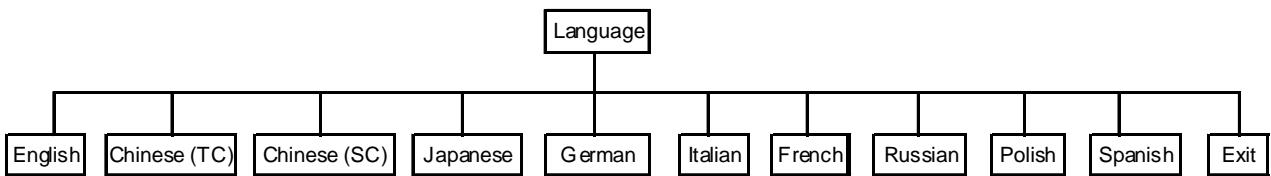

This option is used to setup the language on LCD display.

Press **UP** ⏴ or **DOWN** ⏵ to scroll the cursor to desire language and press **SELECT** to select this option. Press **MENU** ≡ to cancel the setting and return to the previous menu. The default language setting is English.

3.5 Service

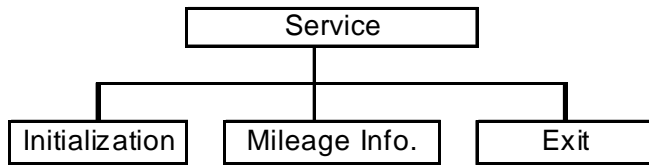

This feature is used to restore printer settings to defaults and display printer mileage information.

3.5.1 Initialization

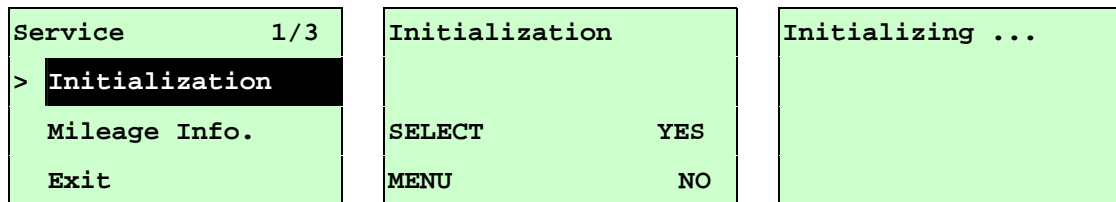

The printer settings are restored to defaults as below once printer is initialized.

Note : *When printer initialization is done, please calibrate the gap or black-mark sensor before printing supplies with gap or black-mark sensor.*

Parameter	Default setting
Speed	2 IPS (50.8 mm/sec)
Density	5.0
Label width	9"(219.5mm)
Label length	15"(101.6mm)
Sensor type	Gap sensor
Gap setting	0.12"(3.0mm)
Print direction	0
Reference point	0,0(upper left corner)
Offset	0
Print mode	Batch mode
Serial port settings	9600 bps, none parity, 8 data bits, 1 stop bit
Code page	850
Country code	001
Clear flash memory	No
Shift X	0
Shift Y	0
Gap sensor sensitivity	3 (Will be reset. Need to re-calibrate the gap)
Bline sensor sensitivity	2 (Will be reset. Need to re-calibrate the gap)
Language	English
IP address	DHCP

5. Printer Specifications

Printer model	DuraLabel 9000
Resolution	300 DPI
Printing method	Thermal Transfer & Direct Thermal
Print speed	Up to 3 ips
Max. print width	215.9mm (8.5"), Center Bias
Max. print length	1270 mm (50")
Enclosure	Sheet metal structure with plastic cover
Physical dimension	470mm(W) x 350 mm(H) x 550mm(D) 18.50" (W) x 13" (H) x 21.65" (D)
Weight	22kg (TBD)
Ribbon	<ul style="list-style-type: none"> ■ 300 M long, 1" core (ink outside) ■ Support color ribbon
Ribbon width	110mm ~ 254.0mm (4.33"~8.66")
Ribbon take up direction	Same as DLP200/300
Label roll capacity	152.4 mm (6") OD
Processor	32-bit ARM9 architecture micro processor, 200MHz
Memory	<ul style="list-style-type: none"> ■ 8MB Flash memory ■ 32MB SDRAM ■ SD flash memory card slot for flash memory expansion
Interface	<ul style="list-style-type: none"> ■ Centronics (SPP mode) ■ USB 2.0 client (full speed) ■ RS232C
Power	Internal switching power supply <ul style="list-style-type: none"> ■ Input: AC 115V/230V, 5A/3A, 50HZ/60HZ
LCD display	<ul style="list-style-type: none"> ■ Graphic type, 122 x 32 pixel, with back light ■ The number of printed label should be shown on LCD display ■ LCD supported language: English
Operation switch, button	Power switch at back side of printer 6 operation buttons (up, down, select, pause, feed, menu)

Sensors	<ul style="list-style-type: none"> ■ Transmissive gap sensor, easy to access when label is loaded ■ Reflective black mark sensor (position adjustable) ■ Transmissive ribbon end sensor (Ribbon end must be transparent) ■ Head open sensor ■ Print head heater element diagnostic
Internal font	<ul style="list-style-type: none"> ■ 8 alpha-numeric bitmap fonts ■ Monotype Imaging true type font engine
Code Page	<ul style="list-style-type: none"> ■ Codepage 437 (English - US) ■ Codepage 850 (Latin 1) ■ Codepage 852 (Latin 2) ■ Codepage 860 (Portuguese) ■ Codepage 863 (French Canadian) ■ Codepage 865 (Nordic) ■ Codepage 857 (Turkish) ■ Codepage 861 (Iceland) ■ Codepage 1252 (Latin 1) ■ Codepage 1250 (Latin 2) ■ Codepage 1254 (Turkish) ■ Latin-1 (ISO-8859-1: Western European) ■ Latin-2 (ISO-8859-2: Central European) ■ Latin-9 (ISO-8859-9: Turkish)
Bar code	<p>1D bar code</p> <p>Code 39, Code 93, Code128UCC, Code128 subsets A.B.C, Codabar, Interleave 2 of 5, EAN-8, EAN-13, EAN-128, UPC-A, UPC-E, EAN and UPC 2(5) digits add-on, MSI, PLESSEY, POSTNET, China POST, 2005 sunrise compliance barcode, RSS code</p> <p>2D bar code</p> <p>PDF-417, Maxicode, DataMatrix, QR code</p>
Font & barcode rotation	0, 90, 180,270 degree
Printing ratio	Full black thickness can't be greater than 12 dots in height
Command set	TSPL-EZ
Media type	Continuous, die-cut, Fan-fold, tag, notched, black mark, perforated, care label (width less than 3 inch)
Media wound type	Outside wound

Media width	101.6~223.5mm (4" ~ 9")
Media thickness	0.025~0.254 mm (0.98mil~10 mil)
Media core diameter	76.2 mm (3")
Label length	25.4~1270 mm (1.0"~50")
Label length (peel mode)	N/A
Label length (cutter mode)	25.4~1270 mm (1.0"~50")
Gap height	Min. 2 mm
Black mark height	Min. 2 mm
Black mark width	Min. 8 mm (0.31")
Printout bias	Vertical: 1 mm max. Horizontal: 1 mm max.
Environment condition	Operation: 5~40°C, 20~85% non-condensing Storage: -40~60°C, 5~90% non-condensing
Safety regulation	CE,FCC Class A
Environmental concern	Comply with RoHS, WEEE
Accessories	<ul style="list-style-type: none"> ■ Software CD ■ Quick start guide ■ USB cord ■ Power cord ■ Supply Guides ■ Ribbon Guides with screws (2) ■ Empty Ribbon supply core
Reliability	<ul style="list-style-type: none"> ■ Platen: 50 km (service part) ■ TPH warranty 1 million inch or 12 months whichever comes first
Cutter	<ul style="list-style-type: none"> ■ Max. width 8.9" ■ Cut thickness 10 mil (including label with liner)
Media protection (option)	HF RFID

6. Troubleshooting

6.1 Common Problems

The following guide lists the most common problems that may be encountered when operating the DuraLabel 9000. If the printer still does not function after all suggested solutions have been invoked, please contact Graphic Products Customer Service for assistance.

Problem	Possible Cause	Recovery Procedure
Power indicator does not illuminate	<ul style="list-style-type: none"> The power cord is not properly connected. 	<ul style="list-style-type: none"> Plug the power cord in printer and outlet. Switch the printer on.
Carriage Open	<ul style="list-style-type: none"> The printer carriage is open. 	<ul style="list-style-type: none"> Please close the print head mechanism.
No Ribbon	<ul style="list-style-type: none"> Out of ribbon. The ribbon is installed incorrectly. 	<ul style="list-style-type: none"> Supply a new ribbon roll. Please refer to the steps in user's guide to reinstall the ribbon.
No Paper	<ul style="list-style-type: none"> Out of label supply. The label is installed incorrectly. Gap/black-mark sensor is not calibrated. 	<ul style="list-style-type: none"> Supply a new label supply roll. Please refer to the steps in user's guide to reinstall the label supply roll. Calibrate the gap/black-mark sensor, when using gap/black-mark material.
Paper Jam	<ul style="list-style-type: none"> Gap/black-mark sensor is not set properly. Make sure label supply size is set properly. Labels may be stuck inside the printer mechanism. 	<ul style="list-style-type: none"> Verify media is loaded correctly and adjust sensor to appropriate location. Calibrate the gap/black-mark sensor. Set label supply size correctly.
UP: Fwd. DOWN: Rev. MENU: Exit	<ul style="list-style-type: none"> Cutter jam. There is no cutter installed on the printer. Cutter PCB is damaged. 	<ul style="list-style-type: none"> If the cutter module is installed, please press UP or DOWN key to rotate the cutter up or down to move the blade back to the right position. Remove the label. Make sure the thickness of label is less than 0.254 mm (10mil) Replace a cutter PCB.

<p>Not Printing</p>	<ul style="list-style-type: none"> · Cable is not well connected to serial or USB interface or parallel port. · The serial port cable pin configuration is not pin to pin connected. 	<ul style="list-style-type: none"> · Re-connect cable to interface. · If using serial cable, <ul style="list-style-type: none"> - Please replace the cable with pin to pin connected. - Check the baud rate setting. The default baud rate setting of printer is 9600,n,8,1. · If using the Ethernet cable, <ul style="list-style-type: none"> - Check if the Ethernet RJ-45 connector green LED is lit on. - Check if the Ethernet RJ-45 connector amber LED is blinking. - Check if the printer gets the IP address when using DHCP mode. - Check if the IP address is correct when using the static IP address. - Wait a few seconds let the printer get the communication with the server then check the IP address setting again. · Change a new cable. · Ribbon and media are not compatible. · Verify the ribbon-inked side faces correct way. · Reload the ribbon again. · Clean the print head. · The print density setting is incorrect. · Print head's harness connector is not well connected with print heat. Turn off the printer and plug the connector again. · Check if the stepping motor is plugging in the right connector. · Check your program if there is a command PRINT at the end of the file and it must have CRLF at the end of each command line.
<p>Memory full (FLASH / DRAM)</p>	<ul style="list-style-type: none"> · The space of FLASH/DRAM is full. 	<ul style="list-style-type: none"> · Delete unused files in the FLASH/DRAM. · The max. numbers of file of DRAM is 256 files. · The max. user addressable memory space of DRAM is 2048 KB. · The max. numbers of file of FLASH is 256 files. · The max. user addressable memory space of FLASH is 6656KB.
<p>SD card is unable to use</p>	<ul style="list-style-type: none"> · SD card is damaged. · SD card doesn't insert correctly. · Use the non-approved SD card manufacturer. 	<ul style="list-style-type: none"> · Use the supported capacity SD card. · Insert the SD card again. · The supported SD card spec. <ul style="list-style-type: none"> - 128MB - 256MB - 512MB - 1GB - 4GB SDHC CLASS 6 · Approved SD card manufacturers; SanDisk, Transcend
<p>PS/2 port does not work</p>	<ul style="list-style-type: none"> · Did not turn off power prior to plug in the PS/2 keyboard. · PS/2 keyboard is damaged. · PS/2 keyboard doesn't plug-in correctly. · There is no BAS file in the printer. 	<ul style="list-style-type: none"> · Turn off printer power prior to plug in the PS/2 keyboard . · Plug the PS/2 keyboard again. · Make sure the keyboard is fine. · Make sure if there is any BAS file downloaded into printer.

Poor Print Quality	<ul style="list-style-type: none"> · Ribbon and media is loaded incorrectly · Dust or adhesive accumulation on the print head. · Print density is not set properly. · Print head element is damaged. · Ribbon and media are incompatible. · The print head pressure is not set properly. 	<ul style="list-style-type: none"> · Reload the supply. · Clean the print head. · Clean the platen roller. · Adjust the print density and print speed. · Run printer self-test and check the print head test pattern if there is dot missing in the pattern. · Change proper ribbon or proper label media. · The release lever does not latch the print head properly.
LCD panel is dark and keys are not working	<ul style="list-style-type: none"> · The cable between main PCB and LCD panel is loose. 	<ul style="list-style-type: none"> · Check if the cable between main PCB and LCD is secured or not.
LCD panel is dark but the LEDs are light	<ul style="list-style-type: none"> · The printer initialization is unsuccessful. 	<ul style="list-style-type: none"> · Turn OFF and ON the printer again. · Initialize the printer.
Label feeding is not stable (skew) when printing	<ul style="list-style-type: none"> · The media guide does not touch the edge of the media. 	<ul style="list-style-type: none"> · If the label is moving to the right side, please move the label guide to left. · If the label is moving to the left side, please move the label guide to right.
Skip labels when printing	<ul style="list-style-type: none"> · Label size is not specified properly. · Sensor sensitivity is not set properly. · The media sensor is covered with dust. 	<ul style="list-style-type: none"> · Check if label size is setup correctly. · Calibrate the sensor by Auto Gap or Manual Gap options. · Clear the GAP/Black-mark sensor by blower.
The left side printout position is incorrect	<ul style="list-style-type: none"> · Wrong label size setup. · The parameter Shift X in LCD menu is incorrect. 	<ul style="list-style-type: none"> · Set the correct label size. · Press [MENU] → [SELECT] x 3 → [DOWN] x 5 → [SELECT] to fine tune the parameter of Shift X.
Missing printing on the left or right side of label	<ul style="list-style-type: none"> · Wrong label size setup. 	<ul style="list-style-type: none"> · Set the correct label size.
RTC time is incorrect when reboot the printer	<ul style="list-style-type: none"> · The battery has run down. 	<ul style="list-style-type: none"> · Check if there is a battery on the main board.
Power and Error LEDs are blinking fast	<ul style="list-style-type: none"> · Power switch OFF and ON too fast. 	<ul style="list-style-type: none"> · Turn off the printer and wait all LEDs are dark, and turn on the printer again.
Wrinkle Problem	<ul style="list-style-type: none"> · Print head pressure is incorrect. · Ribbon installation is incorrect. · Media installation is incorrect. · Print density is incorrect. · Media feeding is incorrect. 	<ul style="list-style-type: none"> · Make sure the adjustable label guides touch the edge of the media. · Make sure label, paper core and ribbon are set at the appropriate settings. Adjust ribbon guides and/or label guides as necessary. · Manually remove wrinkles with hands.
Line on the blank label	<ul style="list-style-type: none"> · The print head is dirty. · The platen roller is dirty. 	<ul style="list-style-type: none"> · Clean the print head. · Clean the platen roller.
Irregular printing	<ul style="list-style-type: none"> · The printer is in Hex Dump mode. · The RS-232 setting is incorrect. 	<ul style="list-style-type: none"> · Turn off and on the printer to skip the dump mode. · Re-set the Rs-232 setting.

7. Maintenance

This session presents the clean tools and methods to maintain your printer.

1. Please use one of following materials to clean the printer.

- Cotton swab (Head cleaner pen)
- Lint-free cloth
- Vacuum / Blower brush
- Ethanol or a solution of IPA and water only

2. The cleaning process is described as following

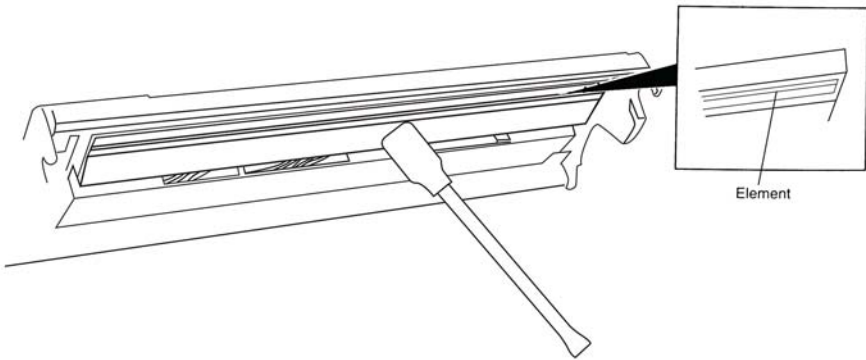
Printer Part	Method	Interval
Print head	1. Always turn off the printer before cleaning the print head. 2. Allow the print head to cool for a minimum of one minute. 3. Use a cotton swab (Head cleaner pen) and 100% ethanol to clean the print head surface.	Clean the print head when changing a new label roll
		
Platen Roller	1. Turn OFF power. 2. Rotate the platen roller and wipe it thoroughly using ethanol or a solution of IPA and water only with a cotton swab, or lint-free cloth.	Clean the platen roller when changing a new label roll
Sensor	Compressed air or vacuum	Monthly
Exterior	Wipe it with water-dampened cloth	As needed
Interior	Brush or vacuum	As needed

Note:

- Do not touch printer head by hand. If you touch it, please use ethanol to clean it.
- Please use ethanol or a solution of IPA and water only to clean the print head.
- Regularly clean the print head and supply sensors when changing the ribbon or vinyl to maintain the printer’s performance and extend the life of the printer.

